



ECOLITE

 **LAURENS**
radiatoren & retro sanitair

Lamellar Heat-Exchanger **Convactor Heaters**



About the Company

The ISAN trademark represents a traditional Czech manufacturer of heating units with a history that goes back more than 60 years. ISAN Radiátory s.r.o. has been involved in the development and manufacture of convectors for over 12 years. First-rate technological procedures and the progressive thinking of our designers and developers invariably guarantee that ISAN products continue to achieve high-level technical and aesthetic parameters, which have allowed them to become the products of choice among both domestic and foreign customers. We export 90% of our production primarily into EU countries.

Our primary objective is customer satisfaction. Product processing consistent with ecological best practice and utmost consideration for the environment goes without saying.

The manufacture conforms to ISO 9001:2015. Moreover, all heating units comply with certification requirements applicable to current statutory regulations of individual countries in order to conform to the most stringent standards. The certification process for the Czech Republic was completed at the Testing Institute for Mechanical Engineering in Brno, notified entity ES1015.

The complete ISAN portfolio consists of a wide range of radiant convectors and lamella-fitted radiators ISAN EXACT, convectors with a lamella heat exchanger ISAN ECOLITE, convectors ISAN TERMO, column radiators ISAN ATOL, ribbed-tube radiators ISAN SPIRAL, glass radiators ISAN JOY and, last but not least, bathroom radiators ISAN MELODY.

ISAN Radiátory s.r.o. specialises in the manufacture of custom-made radiators according to customer requirements and specifications.

Explanatory Notes



marking of an environmentally friendly product with low consumption and economical operation, designed for 24V DC operation



fan-operated convector heater, increased output with forced convection



heating, a convector heater for hot water heating systems with forced circulation



acoustic pressure parameters of fan-operated convector heaters



fan-operated convector heater power input



standard designer convector heater



heaters with rounded corners, increased injury prevention

Contents

About the Company	1
ECOLITE – Basic Information	2
Heater Type Overview	4
Design Options	5
Convector Heater Accessories	6
Fan convector heaters Accessories	8
ECOLITE CUBE	10
LZK Self-standing convector heaters	12
LSK Wall-mounted convector heaters.....	16
LZT Fan-operated self-standing convector heaters	20
LST Fan-operated wall-mounted convector heaters	24
ECOLITE ROUND.....	28
TZK Self-standing convector heaters	30
TSK Wall-mounted convector heaters	34
TZT Fan-operated self-standing convector heaters	38
TST Fan-operated wall-mounted convector heaters	42
LBK Convector Bench.....	46
Atypical convector heaters	48
Pressure loss for self-standing models	50
Pressure loss for wall-mounted models	52
Electrical diagram	54
Acoustics	56
Orientation colour card.....	57
ECOLITE - coding for convector heaters with lamellar heat exchangers	58

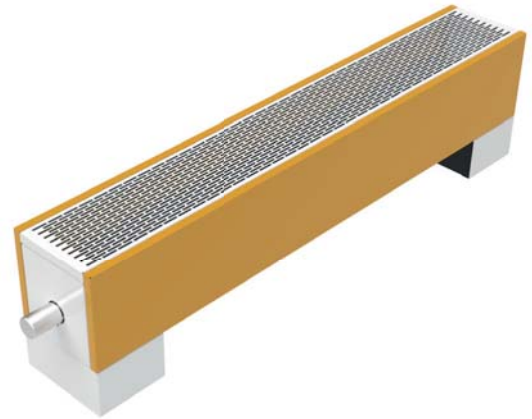

ECOLITE – Basic Information

Application

Convector heaters are generally installed in residential and administrative buildings, office settings and entrance halls, as well as storage facilities, changing rooms and other workplace areas. Individual models allow for installation in front of large glass walls or free-standing or wall mounted installation. Forced circulation models (fan-operated) are suitable for integration with low-temperature systems.

Important features of lamellar heat-exchanger heaters include their low surface temperature and the option to select rounded-corner models that are ideal for children's rooms and other settings where increased safety is a concern.

Function

A "thermal screen" is created in front of a glass surface, which effectively separates the cold surface from the indoor environment. At the same time, air flow prevents condensation of air humidity on the surface. The vertical and horizontal distribution of temperatures within the heated space is even and favourable conditions are created to secure thermal comfort.

The air flow is comparable to heat transmission provided by traditional heating units mounted on walls under windows. As the temperature of the heater cover remains moderate during operation, it can never cause burn injuries. The entire heat output is transferred to the air streaming through the lamellar heat-exchanger inside the heating body.

Operation

The heat output is controlled by a thermostatic head fitted onto the thermostatic valve of each heater. It responds to ambient temperature fluctuations and smoothly controls the flow of the heating fluid through the heat-exchanger.

Another advantage of the heaters lies in their ability to promptly respond to heating requirements, while the low volume of water in the heat-exchanger secures fast warming up to operating temperature.

Fan-operated convector heaters are controlled by a thermostat which regulates fan speed and the flow rate of the heating fluid. The heat output can be increased several-fold by forced convection, which is very useful during periods of extremely cold weather and it can be advantageously combined with low-temperature heating systems. All heater components are designed for safe 24 V DC operation.

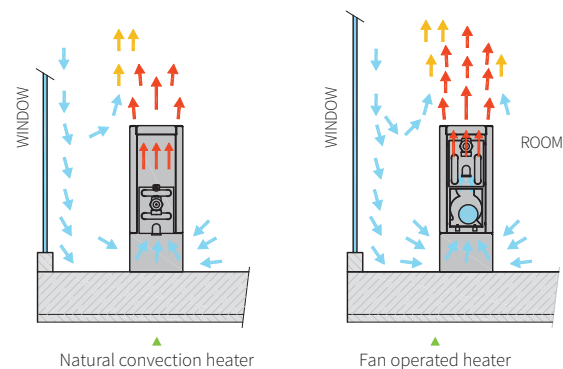

Low-temperature heating systems

High-performance models with modern tangential 24 V DC EC ventilators allow for integration with low temperature heating systems, making use of thermal pumps and other ecological heating sources.

Placement

Convector heaters are normally installed in front of windows to ensure optimum air circulation in front of the glass surface. Ideally, it is best if the unit occupies as much of the width of the window as practically possible. In addition, the height of each unit should be sized with regard to the character of the room as well as the height of the windowsill. Wall-mounted models can be anchored under the windowsill or to one of the inner walls.

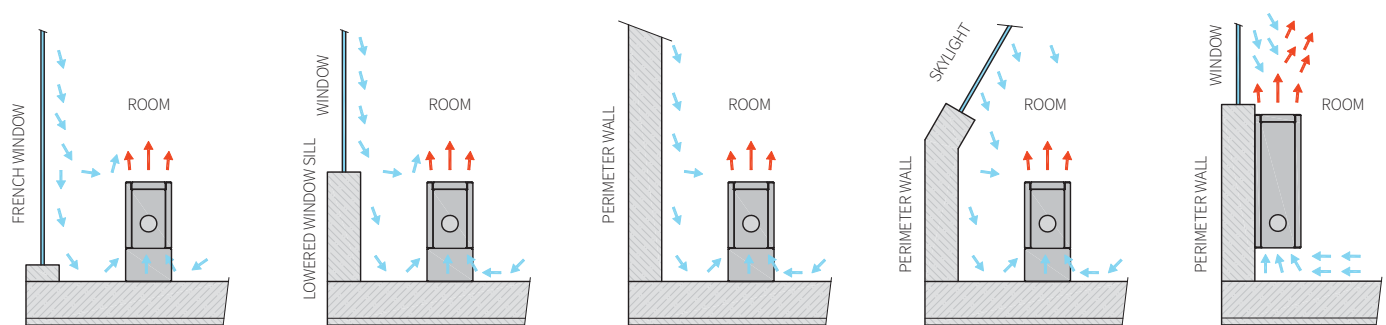

BMS

Convector heaters equipped with EC fan technology in combination with a modern digital thermostat can easily be incorporated into building management systems (BMS). Communication with the superior system is either direct or via a thermostat with an output for KNX protocol communication. For other systems, it is possible to use protocol converters.

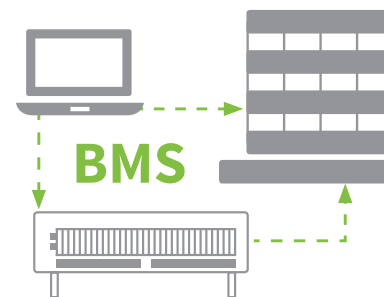

Connecting in the heating system

Lamellar Al-Cu heat exchangers have aluminium lamellas pressed onto a copper pipe through which the heating medium flows. The pipe's outlet and inlet are equipped with a connecting end with internal thread G1/2".

We install a thermostatic valve fitted with an electrothermal actuator on the inlet of the lamellar heat exchanger. The actuator works in the opened/closed mode and controls the flow of the heating medium. It is not necessary to use a thermostatic valve if the temperature of the heating medium is controlled by the heating system (e.g. equithermal system). The way of regulation is to be determined by the designer of the heating and this shall be specified in the project documentation.

A return regulating screw connection shall be used for the outlet. This enables the incorporation of the convector into the heating system from the viewpoint of the hydraulic balancing. Based on the parameters of the screw connection used the designer determines the setting (corresponding to pressure loss at the fitting) and this value shall be specified in the project documentation.

Each exchanger is fitted with an air vent valve. When the heating system is connected and filled air bubbles remain caught in the upper part of the exchanger. These shall be let out through the air vent valve.

How to size the fan-operated convector heater

What room the convector is to be placed in

We always consider output and acoustic parameters of the convector taking into account the room's nature – residential rooms, bedrooms, corridors, offices, theatres, hospital rooms, halls, presentation rooms and others. The convector shall comply with the requirement for thermal output at a selected temperature gradient, however at the same time the operation shall not disturb the user with excessive noise. The noise issue is regulated by the applicable standard, which defined permitted limits for individual types of rooms.



The output of the convector

The tables contain output data for thermal gradient 75/65/20°C, standardized output according to standard EN 442-2 and DIN 16 430 (Fan-operated convectors). This standard also defines the procedure for conversion to other thermal gradients. The second table presents a converted thermal gradient of 55/45/20°C and a fast approximate conversion for gradients of 90/70/20°C and 70/55/20°C.

- Convert the output to the required thermal gradient, check acoustic parameters.
- It is not a problem if the calculated output is higher than the required one – the automatic regulation functions from the lowest revs per the output that is equal to the current thermal loss in the room, the convector will not overheat, on the contrary it will function with less noise (it will achieve the required output at lower revs), the comfort temperature in the room will be achieved faster

Warranty conditions

The warranty provided by the seller applies to tightness, surface finish, specified values of thermal outputs and pressure losses of heating bodies professionally installed in the closed hot water system according to applicable standards and regulations, including corrosive properties of the heat transferring medium, which shall be used exclusively for heating and never for other utility purposes. Bodies with power input shall be installed professionally according to applicable standards and regulations specifying the placement of appliances. Ecolite convectors with the fan with IP20 protection cover – dry environment.

Warranty periods

The warranty period for convectors Ecolite 5 years.

Heater Type Overview

Self-standing convector heaters



TZK ▶ ◀ LZK

NATURAL CONVECTION HEATER



LZK - model CUBE page 12
TZK - model ROUND page 30



TZT ▶ ◀ LZT

FAN OPERATED CONVECTOR HEATER



LZT - model CUBE page 20
TZT - model ROUND page 38

Wall-mounted convector heaters



TSK ▶ ◀ LSK

NATURAL CONVECTION HEATER



LSK - model CUBE page 16
TSK - model ROUND page 34



TST ▶ ◀ LST

FAN OPERATED CONVECTOR HEATER



LST - model CUBE page 24
TST - model ROUND page 42

Convector heater modifications

In addition to the classification of designer ECOLITE heaters into round and square models, other convector heater parameters can also be customised to meet your needs.

- Heater grille selection
- Stands and anchoring
- Colour variations of heaters or individual components
- Customer-specified front side print design
- Connection type (e.g. set in the wall)
- Convector heater with an integrated voltage supply

Structural heater modifications with adapted suction positioning are also available.

- Bottom suction - top exhaust (standard)
- Bottom suction - forward exhaust (standard)
- Forward suction - top exhaust
- Forward suction and exhaust

▶ For more structural modifications, see page 48.



Design Options

Grilles

The grille design is specified upon ordering. The grille is a fixed and integral part of the convector heater; it may not be removed to tamper with inner components of the heater. Each grille is carefully selected to match the interior as well as to achieve its purpose in different environments.

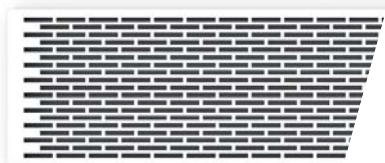

RECTANGULAR HOLES - TYPE R

- steel grille with a surface finish
- narrow slots prevent objects from falling inside the heater
- 30 x 5 mm rectangular holes

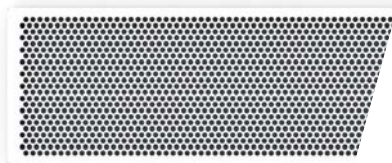

ROUND HOLES - TYPE C

- steel grille with a surface finish
- closely spaced round holes prevent objects from falling or being inserted inside the heater
- designer top grille with \varnothing 6 mm holes
- safe installation

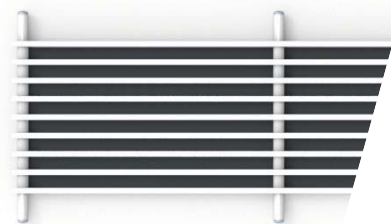

LINEAR GRILLE - TYPE L

- aluminium longitudinal slats with a surface finish
- designer model, will accentuate the linear form of the convector heater
- aluminium 18 x 5 (2.5) mm T-section
- spray-painted or provided with anodised aluminium finish in nature, black or bronze colours

Convectors stands, installation on ground

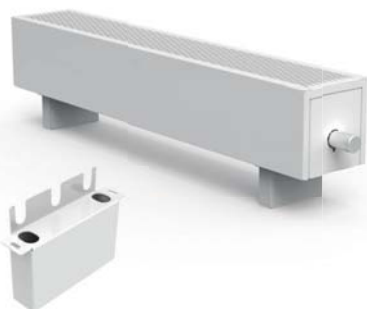

BLOCK STANDS - TYPE K

- subtle design
- inconspicuous floor mounting
- steel stand with a surface finish

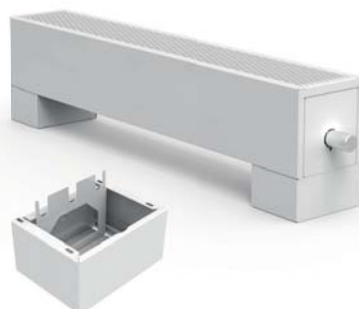

COVER STANDS - TYPE S

- robust design
- neatly covered water piping
- steel stand with a surface finish

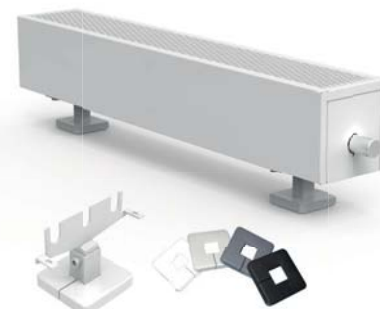

SUBFLOOR STANDS- TYPE H

- stand height to order
- installed below the final flooring level
- openings in the floor finish can be covered with a plastic cover (available in 4 colour variations)

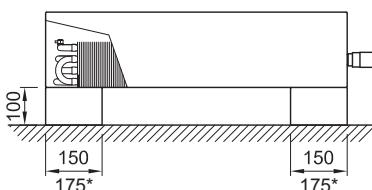
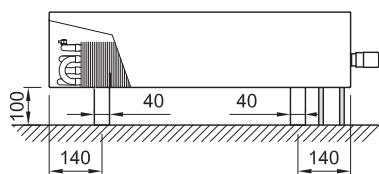

* Fan-operated convector heaters LZT and TZT

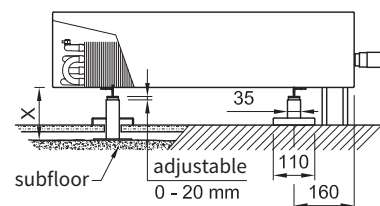

Convactor with bench

Some self-standing models LZK can be equipped with a wooden board, more on page 46.

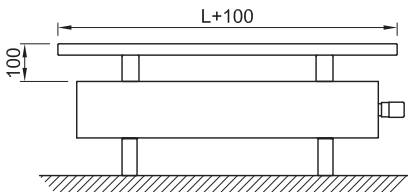

Bottom safety grille for wall models LSK, TSK

Where there is an increased risk of an injury touching the lamellar heat exchanger fin below the convector it is possible to order a bottom safety grille.



Convector heater accessories

LZK, LSK, TZK, TSK

Thermostatic heads

They regulate the flow of heating medium in convectors with natural convection. They proportionally maintain the desired room temperature. It is possible to use alternative thermostat heads with the connection thread M30x1,5.



SENSITIVE CHROME
Thermostatic head chrome
Code: 484000360



SENSITIVE STAINLESS STEEL
Thermostatic head stainless steel
Code: 484000370



SENSITIVE WHITE
Thermostatic head white
Code: 484000350

Thermostats

Z-RT001 ROOM THERMOSTAT FOR FLOW CONTROL IN CONVECTORS WITHOUT FAN

The mechanical room thermostat Z-RT001. In dependence on required temperature it controls the flow of heating medium in the heat exchanger in convectors with natural convection. It controls electrothermal actuators Z-TS24 with a switched power supply 24 V DC (DR). Without the power supply it directly controls the electrothermal actuator Z-TS230 working with the voltage of 230 V AC. Function opened/closed.

Parameters

- Temperature range: 10 to 30 °C
- Operating voltage: 24 V DC or 230 V AC
- The number of controlled electrothermal actuators:
230 V AC - 30×Z-TS230
- Protection: IP30
- Colour: white
- Dimension: 83×83×40 mm



Z-TF001 ROOM THERMOSTAT with a thermostatic head with a capillary

For the flow control in convectors without fan

The thermostatic head Z-TF001 with remote control with a liquid sensor is meant for the control of thermostatic valves of convectors. The temperature is regulated in dependence on the user's requirements without the need for other energy sources. Each convector must have its own Z-TF001, more convectors cannot be controlled!

Parameters

- Thermostatic radiator valve head with remote liquid-filled sensing element
- Temperature range: 9 to 26 °C, antifreeze temperature 9°C
- Mode: proportional control
- Operating temperature: without additional energy, liquid-filled sensing
- Capillara tube length: 5 m
- Body-head connection: M30×1,5 mm
- Dimension: 75×75 mm, sensor ø 50×68 mm
- Colour: white RAL 9010



Electrothermal actuator

Z-TS230 ELECTROTHERMAL ACTUATOR 230 V AC / opened/closed function (without voltage closed)

Parameters

- Input voltage: 230 V AC
- Power consumption: at switch-on 58 VA, input at operation: 2,5 W
- Opening/closing time: 210 s
- Degree of protection: IP54 cover of the casing
- Connection to valve: M30×1,5 mm
- Total height at max. lift: 74 mm
- Colour of actuator and cable: black RAL9005

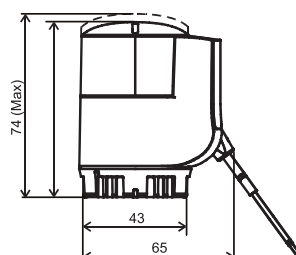

Z-TS230 cable length 3 m

Thermostatic valve

Z-LE001 AXIAL THERMOSTATIC VALVE

Horizontal axial valve, heating medium flow regulation in the system, installation on the heat exchanger's inlet pipe

Parameters

- Heating water, water quality to VDI2035
- Operating temperature max. 130 °C (262°F)
- Operating pressure PN10
- Differential pressure max. 2 bar (29 psi) - max. 0.2 bar (2.9 psi) recommended for quiet operation
- kv(cv)-value 0.72
- Nominal flow 130 kg/h
- Thermostat connection M30 x 1.5
- Closing dimension 11.5 mm
- Stroke 2.5 mm

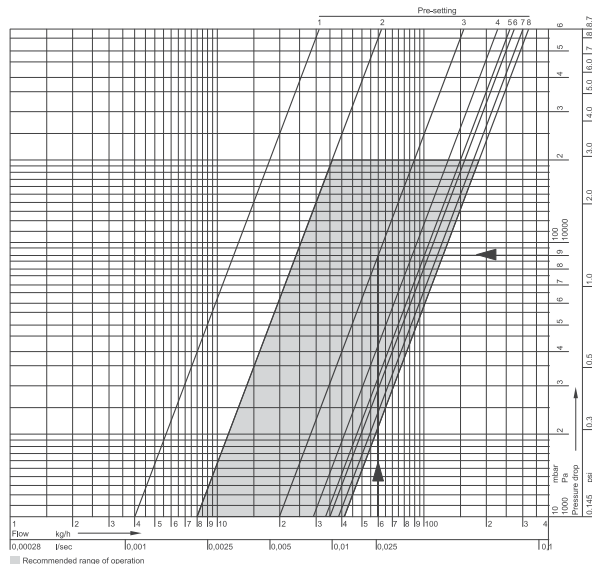

Pre-setting	1	2	3	4	5	6	7	8
xP = 1K (m ³ /h)	0,04	0,06	0,13	0,16	0,19	0,19	0,19	0,19
xP = 2K (m ³ /h)	0,04	0,08	0,2	0,29	0,33	0,35	0,38	0,41
kvs-value (m ³ /h)	0,04	0,09	0,22	0,35	0,43	0,51	0,62	0,72



Z-LE001
horizontal axial valve

Z-TD001 / Z-TE001 THERMOSTATIC VALVE DIRECT AND CORNER

Direct and corner thermostatic valve, heating medium flow regulation in the system, installation on the heat exchanger's inlet pipe direct/corner.

Parameters

- Size: DN15, NF standard
- Connecting thread: M30x1,5 mm
- Max. operating temperature 120 °C
- Max. operating pressure PN10
- Option to change pre-setting of kv-value
- kv value (m³/h) range 0.10-0.89
- kv value (m³/h) for zone 2K 0.52

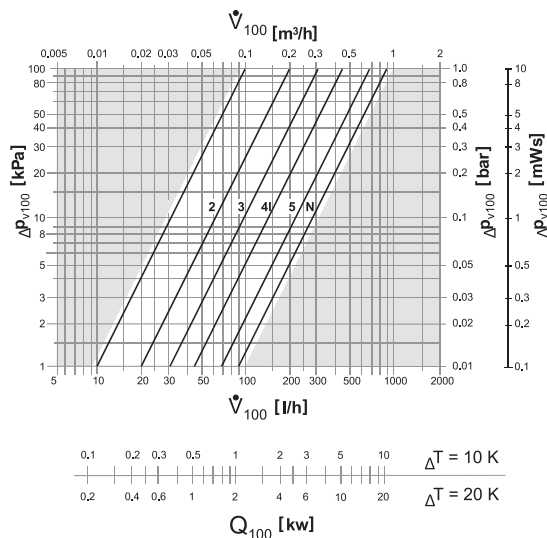

Z-TD001
direct thermostatic valve



Z-TE001
corner thermostatic valve

Lockshield valve direct and corner

Z-RD001 / Z-RE001 LOCKSHIELD VALVE DIRECT AND CORNER

Direct and corner closing and regulation screw connection, flow setting, installation on the exchanger's outlet pipe.

Parameters

- Size: DN15
- Value kvs
 - direct 0.30-1.80
 - corner 0.30-3.00
- Max. operating temperature: 110 °C
- Max. operating overpressure: 10 bar

Kv (°) T - Speed	0,5	0,75	1	1,5	2	2,5	3	3,5	4	5	6	Max.
Kv (m ³ /h) - direct type	0,3	0,4	0,55	0,75	0,91	1,05	1,25	1,33	1,4	1,6	1,7	1,8
Kv (m ³ /h) - corner type	0,2	0,25	0,29	0,4	0,5	0,69	0,8	1	1,2	1,55	1,9	2,2



Z-RD001
direct screw connection



Z-RE001
corner screw connection

Fan convector heaters accessories

LZT, LST, TZT, TST

Controls and a power supply need to be added to convectors to secure their correct function. The temperature in the room is assessed by a room thermostat (RTD201, RTM201), which controls the fan's revs and the flow of heating medium through the heat exchanger. The flow is controlled via an electrothermal actuator (Z-TS24), which opens or closes a thermostatic valve (Z-TD001, Z-TE001). We install the thermostatic valve at the inlet of the heat exchanger. In order to adjust the flow of the heating medium it is necessary to install and set a screw joint (Z-RD001, Z-RE001) at the exchanger's outlet. The entire circuit functions on the basis of safe voltage of 24 V DC, which is provided by a power supply 24 V DC (DR, DRP), which shall be sized according to the number of installed convectors.

Thermostats

RTD201 DIGITAL ROOM THERMOSTAT

For controlling of convectors with fans 24 V DC EC and electrothermal actuators 24 V DC

Setting the thermostat

When putting into operation it is necessary to switch over the DIP switch and set the thermostat's internal parameters.

Description

- Digital room thermostat with backlit LCD display
- Week program, 8 time blocks/day
- Manual or automatic switching of speeds
- Operating modes: Comfort, Economy and Protection
- Colour of front cover: white RAL9003

Optional accessories

- External temperature sensor TE40
- Sensor of exchanger's temperature TE30
- Remote infrared control RC10
- Possibility to connect open window sensor

Parameters

- Temperature range 5-40 °C (Comfort mode)
- Rated voltage 24 V DC
- Power consumption max. 2 VA/1 W
- Control of fans 24 V DC EC 0...10 V DC EC, max. ±5 mA
- Max. connecting of 10 pieces of electrothermal actuators Z-TS24
- Degree of protection IP30
- Ambient temperature 0-50 °C
- Relative humidity <95%
- Dimensions: 128×93×31 mm



Digital thermostat for the **KNX** protocol (building automation) can be ordered under the name **RTD201KN**

RTM201 MANUAL ROOM THERMOSTAT

For controlling of convectors heaters with fans 24 V DC EC and electrothermal actuators 24 V DC.

Description

- controls the three speed levels of the fan using a slider on the thermostat body
- opens the electrothermic actuating system and controls the heating medium flow rate through the convector
- this thermostat makes it possible to connect an exchanger temperature sensor with the following functions:
 - Fan speed blocking in case of insufficient heating medium temperature
 - Heating/cooling switching
 - Anti-freezing protection

Technical specification

- 8...30 °C requested temperature setting
- rated voltage 24 V DC
- max. connecting of 4 pieces of electrothermal actuators Z-TS24
- degree of protection IP30
- ambient temperature 0...+50 °C
- relative humidity < 95 % r.v.
- dimensions: 110×96×35



Power supply

DR60-24 / DR100-24 / DRP240-24 / DRP480-24

Converts the mains voltage of 230 V AC to safe voltage of 24 V DC, power supply made ready for installation on DIN bar

Description

- For the placement of the source provide sufficient space in the switchboard
- Size the output to fit the input of installed bodies and cabling, provide 5% output reserve on the source against calculated consumption
- DR60-24 and DR100-24 may be installed in a box for wall installation



DR60-24, 60 W
24 V DC, 78×93×56 mm



DR100-24, 100 W
24 V DC, 100×93×56 mm



DRP240-24, 240 W
24 V DC, 126×126×100 mm



DRP480-24, 480 W
24 V DC, 227×126×100 mm

Electrothermal actuator

Z-TS24 ELECTROTHERMAL ACTUATOR 24 V DC

Opened/closed function (without voltage closed).

Parameters

- Input voltage: 24 V DC
- Power consumption: at switch-on 6 VA, input at operation: 2,5 W
- Opening/closing time: 270 s
- Degree of protection: IP54 cover of the casing
- Connection to valve: M30×1,5 mm
- Total height at max. lift: 74 mm
- Colour of actuator and cabel: black RAL9005

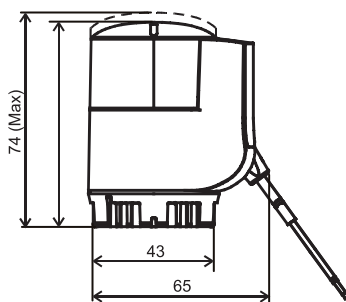

Z-TS24 cable length 3 m

Other accessories

RL10 RELAY

The thermostat RTD201 allows for the connection of 10 pieces of electrothermal actuators at most (RTM201 4 pieces only), if the number of installed actuators is higher use RL10 according to the electric scheme.

Parameters

- voltage in winding 24 V DC
- Degree of protection IP20
- Max. switching current 12 A
- Without voltage: disconnection
- 37×20×39 mm
- Max. operating temperature 60 °C



KP10 BOX FOR POWER SUPPLY

Box to place under plaster, for the installation of the power supply.

Parameters

- Option of installation of DR60-24 and DR100-24
- Attachment to DIN bar
- Installation under plaster, hidden in the wall
- 234×176×79 mm
- For the case when more supplies need to be installed
- When the space in the switchboard is not sufficient



TE30 SEPARATED TEMPERATURE SENSOR (BLOCKING OF REVS) / for thermostat RTD201

Parameters

- Separated temperature sensor monitors temperature of heat exchanger, when the heat exchanger is cold it will not switch on fans
- Connection to thermostat RTD201
- Measuring range 0-40 °C
- Measuring sensor NTC, 3 kΩ at 25 °C
- Measuring accuracy at 25 °C: ±0.3 K
- Cable length ca. 2.5 m, can be adjusted, max. total length 80 m
- Temperature range 0-49°C



TE40 EXTERNAL SPATIAL SENSOR FOR TEMPERATURE / for thermostat RTD201

Parameters

- Measures room temperature on a different spot than the spot where the thermostat is installed
- Connection to thermostat RTD201
- Measuring range 0-40 °C
- Measuring sensor NTC, 3 kΩ at 25 °C
- Measuring accuracy at 25 °C: ±0.3 K
- Degree of protection IP30
- Operating temperature 0-50 °C
- Relative humidity <85 %
- White colour RAL9003
- 97×100×36mm



RC10 REMOTE CONTROL / for thermostat RTD201, Infrared

IRA211 is an infrared control for use with room thermostat RTD201. Communication between the remote control and the spatial regulator is one way. Current setting is shown on the display. Any change carried out directly on the spatial regulator will not be synchronized with the remote control.

Parameters

- Operating mode selection: Comfort, Automatic with a time mode or Protective mode
- Change of the setting of required spatial temperature in the Comfort mode
- Selection of the fan's operating mode: Automatic or manual selection of the fan's speed
- Operating distance (infrared transceiver), distance ≤ 7.5 m, angle ≤ ± 30 °



Thermostatic valves and Lockshield valve

see accessories for convectors with natural convection page 7



ECOLITE CUBE

Self-Standing and Wall-Mounted Convective Heaters

A designer element of contemporary buildings with smooth surfaces, grille and stand variations and colour combinations to match your interior decor.

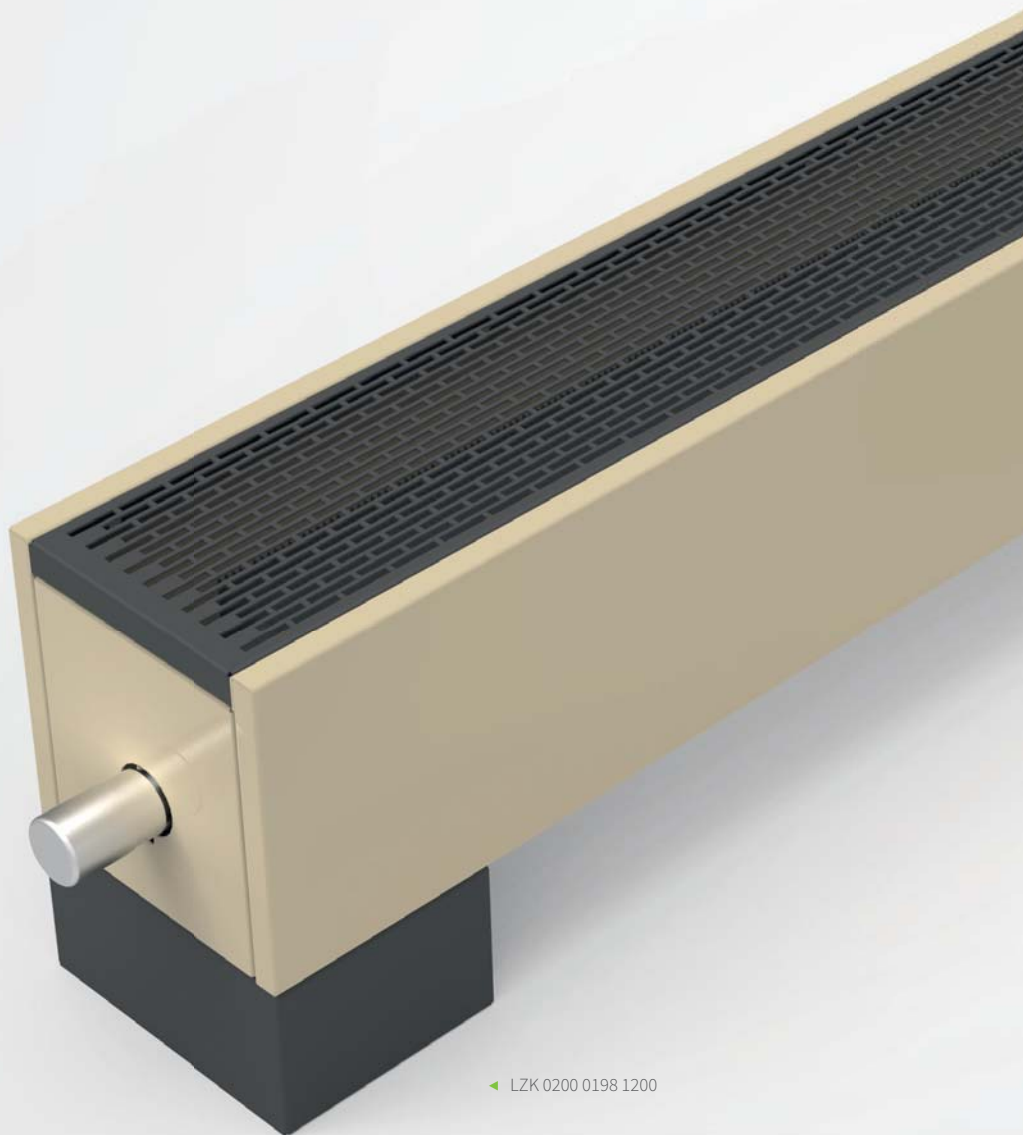

◀ LZX 0200 0198 1200

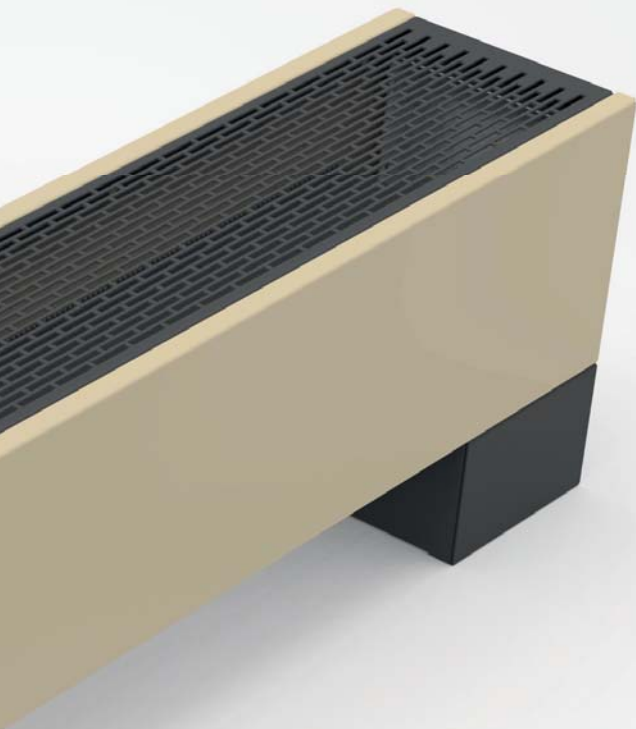

◀ LZT 0350 0138 1000



◀ LST 0500 0122 1000



◀ LSK 0400 0122 0800

LZK Self-standing convector heaters

Convector heaters with lamellar heat-exchangers are popular for their simple design. They find their application especially at locations where larger glass surfaces, such as French windows, shop windows or walls exposed to cold air, need to be thermally screened. However, they also provide an elegant substitute for standard panel radiators.

A range of grille options and stands for floor mounting allows the designer to perfectly match the heater to the interior.

The casing, which forms a chimney shaft, helps optimise the heater function.

- Shopping malls, car showrooms, airport lounges
- Offices, administrative buildings
- Hotels
- Entrance areas, hallways, lobbies



The surface temperature of the heater cover never exceeds **43°C MAX**



Standard Equipment

Cover	surface-treated steel sheet metal with an epoxy polyester powder coating
Grille	round or rectangular holes as per order specifications; the linear grille is securely attached to the cover
Heat-exchanger	Al-Cu lamellar heat-exchanger with a air vent valve, 2 × G1/2" inner connection threads
Valve	axial thermostatic valve, M30 x 1.5 thread with a 2.5 mm pitch (not supplied with side connection configuration)
Mounting	floor anchor stands as per order specifications

Operating Conditions

Max. operating temp.	110°C
Max. operating excess pressure	1 MPa (10 bar)
Protection	IP20
Ambient conditions	temperature T = +2 to +40°C humidity Rh = 20 to 70%

Convector Heater Options and Size Variations

Standard valve connection V

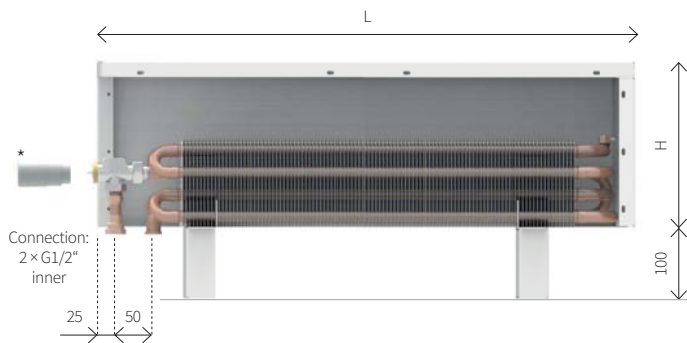

* thermostatic head not supplied with the heater

Side connection B

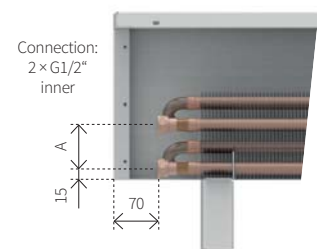

H [mm]	A [mm]
90	30
150-600	60

Convector heater size variations

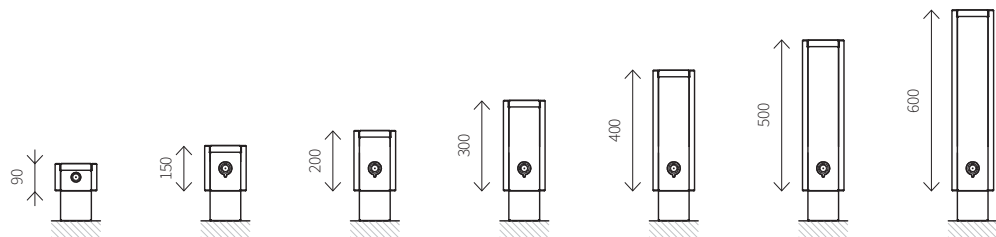

Height H [mm]	90	150	200	300	400	500	600
Width W [mm]	138	138	138	138	138	138	138
	198	198	198	198	198	198	198
	258	258	258	258	258	258	258
Length L [mm]	400-2800	400-2800	400-2800	400-2800	400-2000	400-1600	400-1600

Component parts of the convector heater

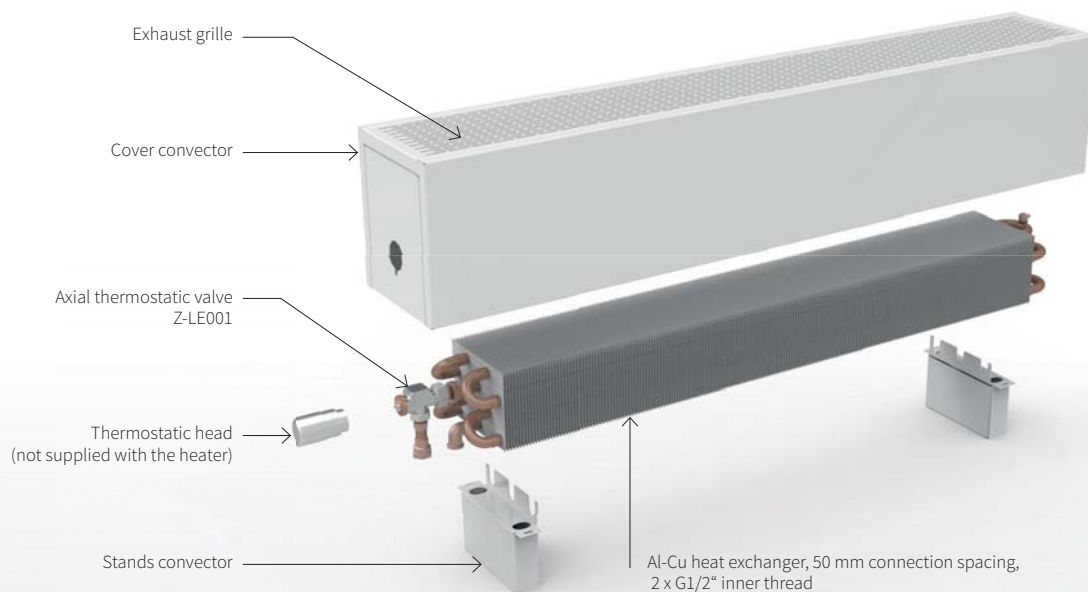

Accessories



► Details of accessories on the page 6

Grilles



Grille R
- rectangular holes



Grille C
- round holes

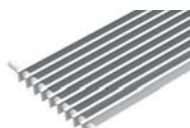

Grille L
- linear grille

tip Order grilles and stands in colours that vary from the cover to brighten up your interior

► Colour design options and grille details, page 5

Stands



Stand K
- floor mounting
- inconspicuous
- height 100 mm



Stand S
- self-standing model
- cover water piping
- height 100 mm
(cannot be used for B connection)



Stand H
- subfloor mounting
- option of plastic cap
- height to order

Number of stands as per the body length

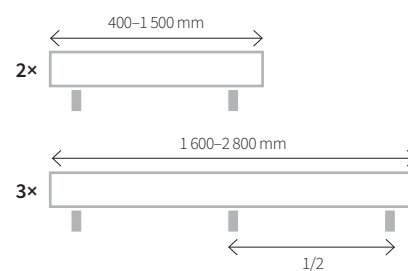

Coding

LZK	0150	0138	0400	C	01	R	1	V	L	K	
Model	Height H	Width W	Length L	Material	Colour	Grille	Grille colour	Connection type	Connection side	Stands	Atypical
LZK	0090 mm 0150 mm 0200 mm 0300 mm 0400 mm 0500 mm 0600 mm	0138 mm 0198 mm 0258 mm	0400 mm 0500 mm ... 1200 mm 1400 mm ... 2800 mm	C Sheet steel with surface finish and an epoxy polyester powder coating	As per RAL colour chart Structured colours Metallic paint colours See colour chart, page 57	R rectangular holes C round holes L linear grille	1 Same as cover colour 9 Grille in different colour	V With axial thermostatic valve, bottom connection, 50 mm spacing B Side connection, 60 mm spacing, valve not included in the delivery	L Left side R Right side	K Inconspicuous, subtle S Water piping cover H Subfloor mounting	Empty position for standard A In non-standard heater configurations

► Other options, see page 59

LZK - Self-standing convectors heating output

Width 138 mm

75/65/20°C	Height [mm] / Heating output [W]						
Length [mm]	90	150	200	300	400	500	600
400	113	179	196	221	241	258	272
500	161	235	256	290	316	338	357
600	209	314	342	386	421	450	476
700	256	381	415	469	511	547	578
800	304	448	488	552	601	643	679
900	352	515	561	634	692	740	781
1000	400	582	635	717	782	836	883
1100	447	649	708	799	872	932	985
1200	495	716	781	882	962	1029	1087
1400	590	850	927	1047	1142	1221	1290
1600	702	1007	1098	1240	1353	1446	1528
1800	797	1141	1244	1406	1533		
2000	893	1275	1391	1571	1713		
2200	988	1409	1537	1736			
2400	1083	1544	1683	1901			
2600	1179	1678	1829	2067			
2800	1274	1812	1976	2232			
Exponent n [-]	1,42	1,42	1,42	1,42	1,42	1,42	1,42

55/45/20°C	Height [mm] / Heating output [W]						
Length [mm]	90	150	200	300	400	500	600
400	55	87	95	107	117	125	132
500	78	114	124	140	153	164	173
600	101	152	166	187	204	218	230
700	124	184	201	227	248	265	280
800	147	217	236	267	291	311	329
900	170	249	272	307	335	358	378
1000	193	282	307	347	378	405	427
1100	217	314	343	387	422	451	477
1200	240	347	378	427	466	498	526
1400	286	412	449	507	553	591	624
1600	340	487	531	600	655	700	740
1800	386	552	602	680	742		
2000	432	617	673	760	829		
2200	478	682	744	840			
2400	525	747	815	920			
2600	571	812	885	1000			
2800	617	877	956	1080			
Exponent n [-]	1,42	1,42	1,42	1,42	1,42	1,42	1,42

Width 198 mm

75/65/20°C	Height [mm] / Heating output [W]						
Length [mm]	90	150	200	300	400	500	600
400	191	293	320	363	397	426	450
500	271	384	419	476	520	558	590
600	352	511	559	634	694	744	787
700	432	621	679	770	842	903	955
800	513	730	799	906	991	1062	1124
900	593	840	918	1042	1139	1221	1292
1000	673	949	1038	1177	1287	1380	1461
1100	754	1058	1157	1313	1436	1539	1629
1200	834	1168	1277	1449	1584	1698	1797
1400	995	1386	1516	1720	1881	2016	2134
1600	1183	1642	1796	2037	2228	2388	2527
1800	1344	1861	2035	2309	2525		
2000	1504	2080	2274	2580	2822		
2200	1665	2298	2514	2852			
2400	1826	2517	2753	3123			
2600	1987	2736	2992	3394			
2800	2148	2955	3231	3666			
Exponent n [-]	1,42	1,43	1,43	1,43	1,43	1,43	1,43

55/45/20°C	Height [mm] / Heating output [W]						
Length [mm]	90	150	200	300	400	500	600
400	93	141	154	175	191	205	217
500	132	185	202	229	251	269	285
600	170	247	270	306	335	359	380
700	209	299	327	371	406	435	461
800	248	352	385	437	478	512	542
900	287	405	443	502	549	589	623
1000	326	458	500	568	621	665	704
1100	365	510	558	633	692	742	785
1200	404	563	616	698	764	819	867
1400	482	668	731	829	907	972	1029
1600	573	792	866	982	1074	1151	1219
1800	651	897	981	1113	1217		
2000	729	1003	1097	1244	1360		
2200	807	1108	1212	1375			
2400	885	1214	1327	1506			
2600	963	1319	1443	1637			
2800	1041	1424	1557	1767			
Exponent n [-]	1,42	1,43	1,43	1,43	1,43	1,43	1,43

Width 258 mm

75/65/20°C	Height [mm] / Heating output [W]						
Length [mm]	90	150	200	300	400	500	600
400	266	414	448	501	543	577	607
500	377	543	587	657	711	757	796
600	489	723	783	876	949	1009	1061
700	601	878	951	1063	1151	1225	1288
800	713	1033	1118	1251	1354	1440	1515
900	825	1188	1286	1438	1557	1656	1742
1000	937	1342	1453	1626	1760	1872	1969
1100	1048	1497	1621	1813	1963	2088	2196
1200	1160	1652	1788	2000	2166	2303	2422
1400	1384	1961	2124	2375	2572	2735	2876
1600	1645	2323	2515	2813	3046	3239	3407
1800	1869	2632	2850	3188	3452		
2000	2093	2942	3185	3563	3857		
2200	2316	3251	3520	3937			
2400	2540	3561	3855	4312			
2600	2764	3870	4190	4687			
2800	2987	4180	4526	5062			
Exponent n [-]	1,42	1,45	1,45	1,45	1,45	1,45	1,45

55/45/20°C	Height [mm] / Heating output [W]						
Length [mm]	90	150	200	300	400	500	600
400	129	197	214	239	259	275	289
500	183	259	280	313	339	361	379
600	237	345	373	418	452	481	506
700	291	419	453	507	549	584	614
800	345	492	533	596	646	687	722
900	399	566	613	686	742	790	830
1000	453	640	693	775	839	892	939
1100	507	714	773	864	936	995	1047
1200	561	788	853	954	1033	1098	1155
1400	670	935	1012	1132	1226	1304	1371
1600	796	1108	1199	1341	1452	1544	1624
1800	904	1255	1359	1520	1646		
2000	1013	1403	1519	1699	1839		
2200	1121	1550	1678	1877			
2400	1229	1698	1838	2056			
2600	1337	1845	1998	2235			
2800	1446	1993	2158	2413			
Exponent n [-]	1,42	1,45	1,45	1,45	1,45	1,45	1,45

LZK - Heating output recalculation for another temperature gradient

To obtain the heating output for a different temperature gradient multiply heating output value at 75/65/20 °C by the below mentioned factor **f**.

Example

Heating output of the convector LZK 0200 0138 2000 for temperature gradient 70/55°C

1. Output 75/65/20 °C = 1 391 W
2. Factor from the table for 70/55/20 °C at 138 width: f = 0.794
3. Output 70/55/20 °C = f × 1391 = 1 104 W

Width 138 mm					
Height [mm]	90/70 °C	82/71 °C	70/55 °C	70/50°C	50/40 °C
90	1,295	1,190	0,794	0,707	0,367
150	1,295	1,190	0,794	0,707	0,367
200	1,295	1,190	0,794	0,707	0,367
300	1,295	1,190	0,794	0,707	0,367
400	1,295	1,190	0,794	0,707	0,367
500	1,295	1,190	0,794	0,707	0,367
600	1,295	1,190	0,794	0,707	0,367

Room temperature 20 °C

Width 198 mm					
Height [mm]	90/70 °C	82/71 °C	70/55 °C	70/50°C	50/40 °C
90	1,295	1,190	0,794	0,707	0,367
150	1,303	1,194	0,790	0,701	0,359
200	1,303	1,194	0,790	0,701	0,359
300	1,303	1,194	0,790	0,701	0,359
400	1,303	1,194	0,790	0,701	0,359
500	1,303	1,194	0,790	0,701	0,359
600	1,303	1,194	0,790	0,701	0,359

Room temperature 20 °C

Width 258 mm					
Height [mm]	90/70 °C	82/71 °C	70/55 °C	70/50°C	50/40 °C
90	1,295	1,190	0,794	0,707	0,367
150	1,298	1,191	0,793	0,705	0,364
200	1,298	1,191	0,793	0,705	0,364
300	1,298	1,191	0,793	0,705	0,364
400	1,298	1,191	0,793	0,705	0,364
500	1,298	1,191	0,793	0,705	0,364
600	1,298	1,191	0,793	0,705	0,364

Room temperature 20 °C

Recalculation to other temperature gradients

Convector heating output reckoning follows by recalculation of the standardized output Q_n 75/65/20 °C

$$Q = Q_n \cdot \Psi \cdot (\Delta T / 50)^n \text{ [W]; where } \Delta T = ((T_1 + T_2) / 2) - T_i \text{ [}^\circ\text{C]}$$

- Q_n [W] heating output for temperature gradient
- Ψ [-] mass rate of flow coefficient (for current flow rate $\Psi = 1$)
- T_1 [°C] input water temperature
- T_2 [°C] output water temperature
- T_i [°C] temperature in the room
- n [-] temperature exponent

Heating water flow rate through exchanger

To reach the required heating output we determine the desired flow of heating water through the convector exchanger. We calculate it from heating output of the convector for the selected input and output temperatures of heating water.

$$M = 0,86 \cdot Q / (T_1 - T_2) \text{ [kg / h]}$$

- M [kg/h] mass rate of flow, heating water flowing through exchanger
- Q [W] convector heating output
- $T_1 - T_2$ [°C] difference between input and output temperature
- 0,86** invariable for recalculation of units

Table of hydraulic parameters of exchangers

For hydraulic parameters of exchangers see the page 48.

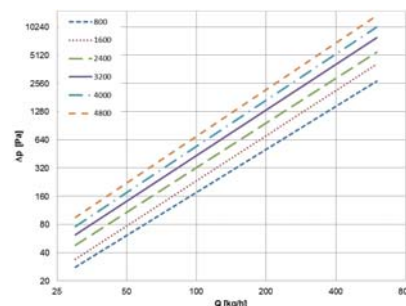

LSK Wall-mounted convector heaters

Wall-mounted convector heaters with smooth front covers will provide an aesthetic complement to your interior. Convection heating is especially suitable for settings where prompt response to temperature fluctuations and low surface temperature are required.

Each heater can be fitted with a variety of exhaust grilles and you can select different colour combinations for individual components of the cover.

For a clean look, select a heater-to-wall connection option.

- Shopping malls, car showrooms, airport lounges
- Offices, administrative buildings
- Hotels
- Entrance areas, lobbies



Standard Equipment

Cover	surface-treated steel sheet metal with an epoxy polyester powder coating
Grille	round or rectangular holes as per order specifications; the linear grille* is securely attached to the cover
Heat-exchanger	Al-Cu lamellar heat-exchanger with a air vent valve, 2 × G1/2" inner connection threads
Valve	axial thermostatic valve, M30 x 1.5 thread with a 2.5 mm pitch (not supplied with side connection configuration)
Mounting	wall brackets with connecting elements

* not available for height 165 mm

Operating Conditions

Max. operating temp.	110°C
Max. operating excess pressure	1 MPa (10 bar)
Protection	IP20
Ambient conditions	temperature T = +2 to +40°C humidity Rh = 20 to 70%

Convector Heater Options and Size Variations

Standard valve connection V

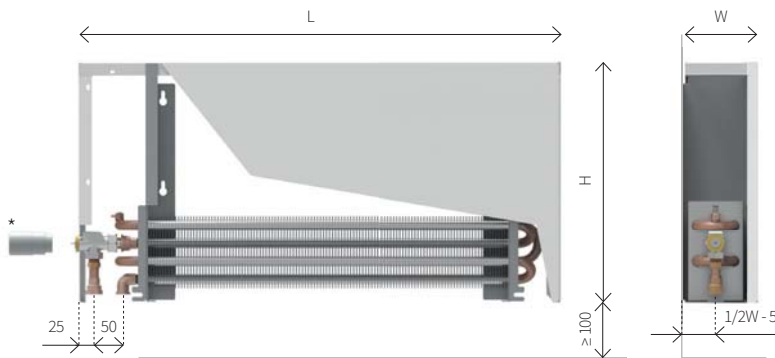

* thermostatic head not supplied with the heater
** not available for W = 82 mm

Convector heater size variations

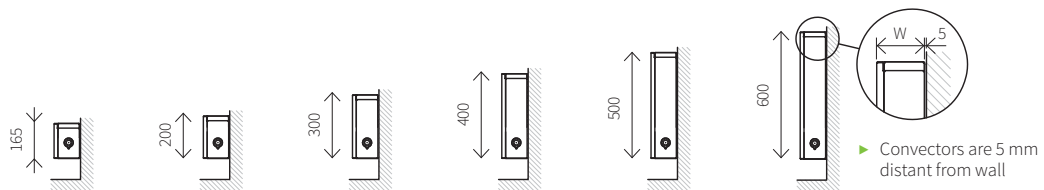

Height H [mm]	165	200	300	400	500	600
Width W [mm]	122	122	122	122	122	122
	182	182	182	182	182	182
	242	242	242	242	242	242
Length L [mm]	400-2800	400-2800	400-2800	400-2000	400-1600	400-1600

Component parts of the convector heater

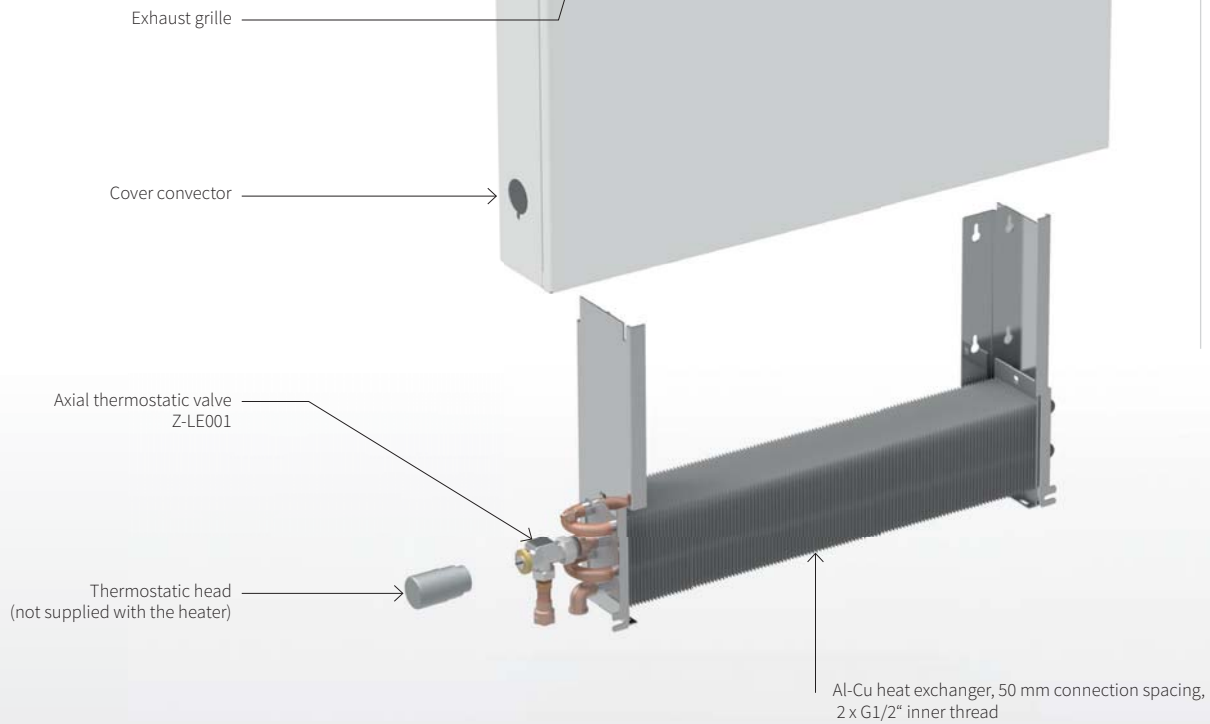

Accessories



► Details of accessories on the page 6

Grilles



Grille R
- rectangular holes

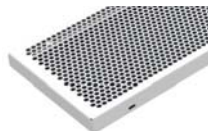

Grille C
- round holes



Grille L
- linear grille
(Not available for height 165 mm.)

tip Order grilles and stands in colours that vary from the cover to brighten up your interior

► Options and grille details, page 5

Brackets

W brackets

Wall brackets for attaching heat exchanger and convector cover are parts of the convector.



Number of brackets as per the body length

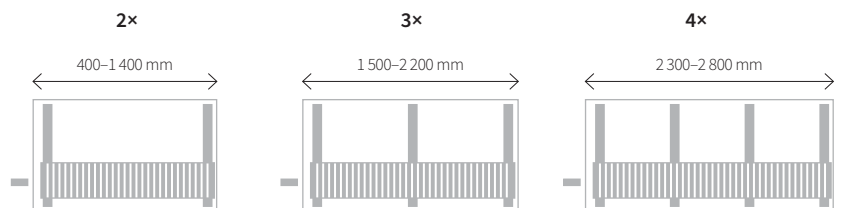

Coding

LSK	0300	0182	1200	C	01	R	1	V	L	W	
Model	Height H	Width W	Length L	Material	Colour	Grille	Grille colour	Connection type	Connection side	Brackets	Atypical
LSK	0165 mm 0200 mm 0300 mm 0400 mm 0500 mm 0600 mm	0082 mm 0122 mm 0182 mm ... 0242 mm	0400 mm 0500 mm ... 1200 mm 1400 mm ... 2800 mm	C Sheet steel with surface finish and an epoxy polyester powder coating	As per RAL colour chart Structured colours Metallic paint colours See colour chart, page 57	R rectangular holes C round holes L linear grille	1 Same as cover colour 9 Grille in different colour	V With valve, bottom connection B Side connection Y With valve, connection to the wall (n/a for W=82 mm) Z connection to the wall without a hole in the cover (n/a for W=82 mm)	L Left side R Right side	W brackets for wall mounting	A In non-standard heater configurations

► Other options, see page 59.

LSK - Wall-mounted convectors heating output

Width 82 mm

75/65/20°C	Height [mm] / Heating output [W]				
Length [mm]	200	300	400	500	600
400	87	105	125	139	150
500	130	158	188	208	225
600	174	210	251	277	300
700	217	262	313	346	375
800	261	315	376	415	450
900	304	367	439	485	525
1000	348	420	501	554	600
1100	391	472	564	623	675
1200	434	525	627	692	750
1400	521	630	752	831	899
1600	608	735	877	969	1049
1800	695	840	1003		
2000	782	945	1128		
2200	869	1050			
2400	956	1155			
2600	1043	1260			
2800	1129	1365			
Exponent n [-]	1,45	1,43	1,41	1,41	1,40

55/45/20°C	Height [mm] / Heating output [W]				
Length [mm]	200	300	400	500	600
400	41	51	61	68	73
500	62	76	92	101	110
600	83	101	122	135	146
700	104	127	153	169	183
800	124	152	183	203	220
900	145	177	214	236	256
1000	166	202	244	270	293
1100	187	228	274	304	329
1200	207	253	305	337	366
1400	249	304	366	405	439
1600	290	354	427	472	512
1800	332	405	488		
2000	373	456	549		
2200	414	506			
2400	456	557			
2600	497	607			
2800	539	658			
Exponent n [-]	1,45	1,43	1,41	1,41	1,40

Width 122 mm

75/65/20°C	Height [mm] / Heating output [W]					
Length [mm]	165	200	300	400	500	600
400	127	137	163	186	207	228
500	190	206	244	279	311	342
600	254	274	326	372	415	456
700	317	343	407	465	518	570
800	381	411	489	558	622	684
900	444	480	570	650	726	798
1000	507	548	652	743	829	912
1100	571	617	733	836	933	1026
1200	634	686	815	929	1036	1140
1400	761	823	977	1115	1244	1368
1600	888	960	1140	1301	1451	1596
1800	1015	1097	1303	1487		
2000	1141	1234	1466	1672		
2200	1268	1371	1629			
2400	1395	1508	1792			
2600	1522	1645	1955			
2800	1649	1782	2118			
Exponent n [-]	1,4	1,4	1,41	1,42	1,43	1,43

55/45/20°C	Height [mm] / Heating output [W]					
Length [mm]	165	200	300	400	500	600
400	62	67	79	90	100	110
500	93	101	119	135	150	164
600	124	134	159	180	200	219
700	155	168	198	225	250	274
800	186	201	238	270	300	329
900	217	235	278	315	350	384
1000	248	268	317	360	400	438
1100	279	302	357	405	450	493
1200	310	335	397	450	500	548
1400	373	402	476	541	600	658
1600	435	469	555	631	700	767
1800	497	536	634	721		
2000	559	603	714	811		
2200	621	670	793			
2400	683	737	872			
2600	745	804	952			
2800	807	871	1031			
Exponent n [-]	1,4	1,4	1,41	1,42	1,43	1,43

Width 182 mm

75/65/20°C	Height [mm] / Heating output [W]					
Length [mm]	165	200	300	400	500	600
400	215	232	276	318	359	401
500	322	348	415	477	539	601
600	429	464	553	636	718	801
700	537	580	691	795	898	1002
800	644	695	829	954	1078	1202
900	752	811	967	1113	1257	1402
1000	859	927	1105	1272	1437	1603
1100	966	1043	1244	1432	1616	1803
1200	1074	1159	1382	1591	1796	2003
1400	1288	1391	1658	1909	2155	2404
1600	1503	1623	1935	2227	2514	2805
1800	1718	1854	2211	2545		
2000	1932	2086	2487	2863		
2200	2147	2318	2764			
2400	2362	2550	3040			
2600	2577	2782	3316			
2800	2791	3013	3593			
Exponent n [-]	1,4	1,4	1,41	1,43	1,44	1,46

55/45/20°C	Height [mm] / Heating output [W]					
Length [mm]	165	200	300	400	500	600
400	105	113	134	153	172	190
500	158	170	201	230	258	286
600	211	227	268	307	344	381
700	263	283	335	383	430	476
800	316	340	403	460	516	571
900	368	397	470	537	602	666
1000	421	453	537	613	688	761
1100	474	510	604	690	774	857
1200	526	567	671	767	859	952
1400	632	680	805	920	1031	1142
1600	737	793	939	1073	1203	1333
1800	842	907	1073	1227		
2000	947	1020	1207	1380		
2200	1052	1133	1342			
2400	1158	1247	1476			
2600	1263	1360	1610			
2800	1368	1473	1744			
Exponent n [-]	1,4	1,4	1,41	1,43	1,44	1,46

LSK - Wall-mounted convectors heating output

Width 242 mm

75/65/20°C	Height [mm] / Heating output [W]					
Length [mm]	165	200	300	400	500	600
400	316	333	384	444	512	590
500	474	499	577	666	767	884
600	632	665	769	887	1023	1179
700	790	831	961	1109	1279	1474
800	947	998	1153	1331	1535	1769
900	1105	1164	1346	1553	1791	2064
1000	1263	1330	1538	1775	2047	2358
1100	1421	1496	1730	1997	2302	2653
1200	1579	1663	1922	2218	2558	2948
1400	1895	1995	2307	2662	3070	3538
1600	2211	2328	2691	3106	3581	4127
1800	2526	2660	3075	3550		
2000	2842	2992	3460	3993		
2200	3158	3325	3844			
2400	3474	3657	4229			
2600	3790	3990	4613			
2800	4105	4322	4997			
Exponent n [-]	1,39	1,4	1,43	1,47	1,5	1,54

55/45/20°C	Height [mm] / Heating output [W]					
Length [mm]	165	200	300	400	500	600
400	156	163	185	210	237	269
500	233	244	277	314	356	403
600	311	326	370	419	475	537
700	389	407	462	524	593	671
800	467	489	555	629	712	805
900	545	570	647	733	830	940
1000	623	651	739	838	949	1074
1100	700	733	832	943	1068	1208
1200	778	814	924	1048	1186	1342
1400	934	977	1109	1257	1423	1611
1600	1089	1140	1294	1467	1661	1879
1800	1245	1303	1479	1676		
2000	1401	1465	1664	1886		
2200	1556	1628	1849			
2400	1712	1791	2033			
2600	1868	1954	2218			
2800	2023	2117	2403			
Exponent n [-]	1,39	1,4	1,43	1,47	1,5	1,54

LSK - Heating output recalculation for another temperature gradient

To obtain the heating output for a different temperature gradient multiply heating output value at 75/65/20 °C by the below mentioned factor **f**.

Width 82 mm					
Height [mm]	90/70 °C	82/71 °C	70/55 °C	70/50°C	50/40 °C
200	1,303	1,194	0,790	0,701	0,359
300	1,298	1,191	0,793	0,705	0,364
400	1,293	1,188	0,795	0,708	0,369
500	1,293	1,188	0,795	0,708	0,369
600	1,291	1,187	0,797	0,710	0,372

Room temperature 20 °C

Width 122 mm					
Height [mm]	90/70 °C	82/71 °C	70/55 °C	70/50°C	50/40 °C
165	1,291	1,187	0,797	0,710	0,372
200	1,291	1,187	0,797	0,710	0,372
300	1,293	1,188	0,795	0,708	0,369
400	1,295	1,190	0,794	0,707	0,367
500	1,298	1,191	0,793	0,705	0,364
600	1,298	1,191	0,793	0,705	0,364

Room temperature 20 °C

Width 182 mm					
Height [mm]	90/70 °C	82/71 °C	70/55 °C	70/50°C	50/40 °C
165	1,291	1,187	0,797	0,710	0,372
200	1,291	1,187	0,797	0,710	0,372
300	1,293	1,188	0,795	0,708	0,369
400	1,298	1,191	0,793	0,705	0,364
500	1,300	1,192	0,791	0,703	0,361
600	1,305	1,195	0,789	0,700	0,356

Room temperature 20 °C

Width 242 mm					
Height [mm]	90/70 °C	82/71 °C	70/55 °C	70/50°C	50/40 °C
165	1,288	1,171	0,798	0,712	0,374
200	1,291	1,172	0,797	0,710	0,372
300	1,298	1,176	0,793	0,705	0,364
400	1,307	1,181	0,787	0,698	0,354
500	1,315	1,185	0,784	0,693	0,346
600	1,324	1,191	0,779	0,686	0,337

Room temperature 20 °C

Example

Heating output of the convector LSK 0200 0122 2000 for temperature gradient 70/55°C

1. Output 75/65/20 °C = 1234 W
2. Factor from the table for 70/55/20 °C at 122 width: f = 0.797
3. Output 70/55/20 °C = f x 1234 = 983 W

Table of hydraulic parameters of exchangers

For hydraulic parameters of exchangers see the page 50.

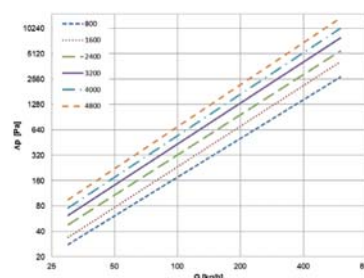

LZT Fan-operated self-standing convector heaters

Convector heaters equipped with a 24V DC fan are suitable for low-temperature heating systems. Their heat output is sufficient even when operated in combination with condensing boilers or heat pumps.

A wall-mounted thermostat continuously controls the speed of the fan, while the convector heater promptly responds to temperature variations in the room and ensures thermal comfort. With the heating system connection and fan control accessories neatly fitted inside the cover, each heater forms a compact, solid unit.

As standard, all convector heaters are supplied with stands which cover up the water connection piping.

- Passive and low-energy houses
- Shopping malls, car showrooms, airport lounges
- Offices, administrative buildings
- Hotels
- Entrance areas, lobbies



Standard Equipment

Cover	surface-treated steel sheet metal with an epoxy polyester powder coating
Grille	round or rectangular holes as per order specifications; the linear grille is securely attached to the cover
Heat-exchanger	black painted Al-Cu lamellar heat-exchanger with an air vent valve, 2 × G1/2" inner threads
Fan	Modern tangential fan with 24 V DC EC motor with high efficiency, rotors protection
Valve	corner thermostatic valve, M30 x 1.5 thread with a 2.5 mm pitch
Mounting	floor anchor stands as per order specifications

Operating Conditions

Max. operating temp.	110°C
Max. operating excess pressure	1 MPa (10 bar)
Protection	IP20
Ambient conditions	temperature T = +2 to +40°C humidity Rh = 20 to 70%
Operating voltage	24 V DC

Convector Heater Options and Size Variations

Standard valve connection V

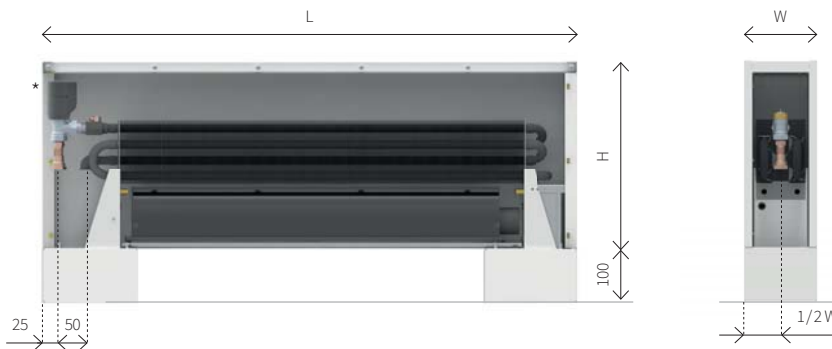

* electrothermal actuator not supplied with the heater

Convector heater size variations

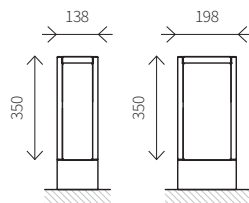

Height H [mm]	350
Width W [mm]	138 198
Length L [mm]	700-2600

Energy saving



Fan convectors operate on safe voltage of 24 V DC. The fan motors have very low consumption of electric power. The speed of fans is continuously commanded by controlling voltage of 0...10 V DC.

Component parts of the convector heater

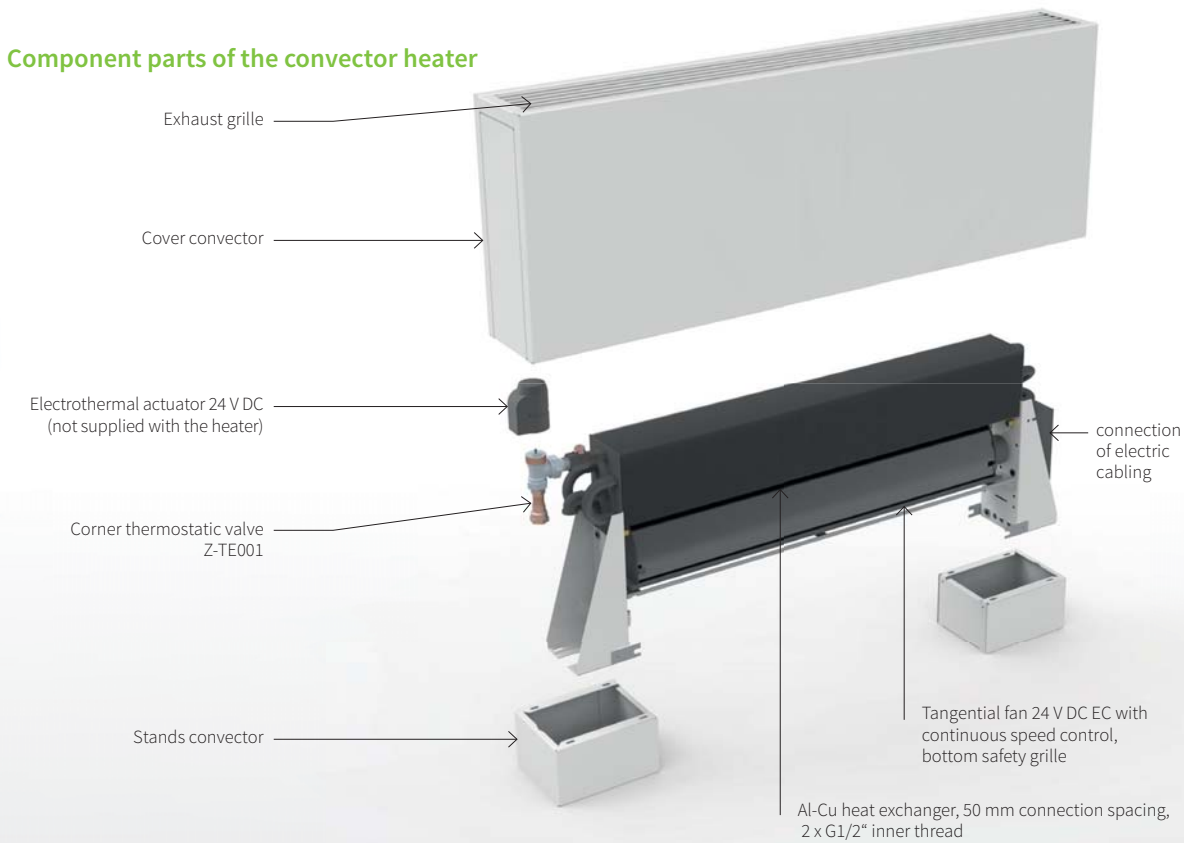

Accessories



► Details of accessories on the page 8

Grilles



Grille R
- rectangular holes

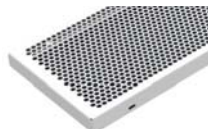

Grille C
- round holes



Grille L
- linear grille

► Colour design options and grille details, page 5

Stands



Stand S
- self-standing model
- cover water piping
- height 100 mm

Number of stands as per the body length

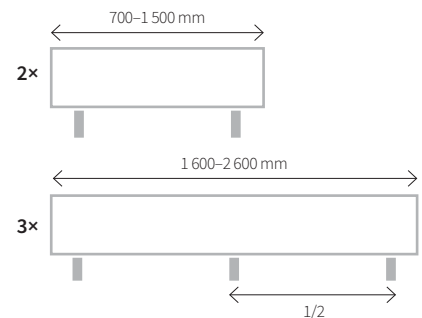

Coding

LZT	0350	0138	0400	C	01	R	1	V	L	S	
Model	Height H	Width W	Length L	Material	Colour	Grille	Grille colour	Connection type	Connection side	Stands	Atypical
LZT	0350 mm	0138 mm 0198 mm	700 mm 1 000 mm 1 200 mm ... 2 400 mm 2 600 mm	C Sheet steel with surface finish and an epoxy polyester powder coating	As per RAL colour chart Structured colours Metallic paint colours See colour chart, page 57	R rectangular holes C round holes L linear grille	1 Same as cover colour 9 Grille in different colour	V With corner thermostatic valve, bottom connection, 50 mm spacing	L Left side R Right side	S Water piping cover	Empty position for standard A In non-standard heater configurations

► Other options, see page 59

LZT - Fan-operated self-standing convectors heating output

Width 138 mm

75/65/20°C		Speed [-] / Heating output [W]				
Length [mm]	0	1	2	3	4 max	
700	243	685	912	1 144	1 313	
1000	401	1 381	1 838	2 305	2 645	
1200	507	1 814	2 415	3 028	3 475	
1400	612	2 218	2 951	3 701	4 247	
1600	718	2 500	3 327	4 173	4 788	
1800	823	2 762	3 676	4 610	5 290	
2000	929	3 195	4 252	5 333	6 120	
2200	1 034	3 629	4 829	6 057	6 950	
2400	1 140	4 032	5 366	6 730	7 723	
2600	1 245	4 435	5 902	7 403	8 495	

55/45/20°C		Speed [-] / Heating output [W]				
Length [mm]	0	1	2	3	4 max	
700	141	398	529	664	762	
1000	233	802	1 067	1 338	1 535	
1200	294	1 053	1 401	1 758	2 017	
1400	355	1 287	1 713	2 148	2 465	
1600	416	1 451	1 931	2 422	2 779	
1800	478	1 603	2 133	2 676	3 070	
2000	539	1 855	2 468	3 096	3 552	
2200	600	2 106	2 803	3 515	4 034	
2400	661	2 340	3 114	3 906	4 482	
2600	723	2 574	3 426	4 297	4 930	

Exponent n = 1,065

Width 198 mm

75/65/20°C		Speed [-] / Heating output [W]				
Length [mm]	0	1	2	3	4 max	
700	385	849	1 118	1 367	1 567	
1000	636	1 710	2 252	2 755	3 158	
1200	803	2 247	2 958	3 620	4 149	
1400	971	2 746	3 616	4 424	5 071	
1600	1 138	3 095	4 076	4 987	5 717	
1800	1 305	3 420	4 503	5 510	6 316	
2000	1 473	3 957	5 210	6 375	7 307	
2200	1 640	4 493	5 917	7 239	8 298	
2400	1 808	4 993	6 574	8 044	9 220	
2600	1 975	5 492	7 232	8 848	10 142	

55/45/20°C		Speed [-] / Heating output [W]				
Length [mm]	0	1	2	3	4 max	
700	214	472	622	761	872	
1000	354	951	1 253	1 533	1 757	
1200	447	1 250	1 646	2 014	2 308	
1400	540	1 528	2 012	2 461	2 821	
1600	633	1 722	2 268	2 774	3 180	
1800	726	1 903	2 505	3 065	3 514	
2000	819	2 201	2 899	3 546	4 065	
2200	912	2 500	3 292	4 027	4 616	
2400	1 006	2 777	3 657	4 475	5 129	
2600	1 099	3 055	4 023	4 922	5 642	

Exponent n = 1,148

LZT - Heating output recalculation for another temperature gradient

To obtain the heating output for a different temperature gradient multiply heating output value at 75/65/20 °C by the below mentioned factor **f**.

Example

Heating output of the convector LZT 0350 0138 1200 or temperature gradient 70/55°C

1. Output 75/65/20 °C = 1814 W
2. Factor from the table for 70/55/20 °C at 138 width: f = 0,841
3. Output 70/55/20 °C = f x 1814 = 1526 W

Height [mm]	90/70 °C	82/71 °C	70/55 °C	70/50 °C	50/40 °C
0350 0138	1,214	1,139	0,841	0,771	0,471
0350 0198	1,233	1,151	0,830	0,755	0,444

Room temperature 20 °C

Heating water flow rate through exchanger

To reach the required heating output we determine the desired flow of heating water through the convector exchanger. We calculate it from heating output of the convector for the selected input and output temperatures of heating water.

$$M = 0,86 * Q / (T1-T2) \text{ [kg / h]}$$

- M [kg/h] mass rate of flow, heating water flowing through exchanger
- Q [W] convector heating output
- T1-T2 [°C] difference between input and output temperature
- 0,86 invariable for recalculation of units

Acoustic pressure [dB(A)]

Length [mm]	Speed [-] / Acoustic pressure [dB(A)]				
	0	1	2	3	4 max
700	-	<20	27	37	45
1000	-	22	30	40	45
1200	-	22	31	41	45
1400	-	22	31	41	45
1600	-	23	32	42	46
1800	-	24	33	43	47
2000	-	25	33	43	48
2200	-	26	34	44	49
2400	-	27	35	45	50
2600	-	28	36	46	51

Recalculation to other temperature gradients

Convector heating output reckoning follows by recalculation of the standardized output Q_n 75/65/20 °C

$$Q = Q_n * \Psi * (\Delta T / 50)^n \text{ [W]; where } \Delta T = ((T1+T2)/2) - T_i \text{ [°C]}$$

- Q_n [W] heating output for temperature gradient
- Ψ [-] mass rate of flow coefficient (for current flow rate $\Psi = 1$)
- T1 [°C] input water temperature
- T2 [°C] output water temperature
- Ti [°C] temperature in the room
- n [-] temperature exponent

Table of hydraulic parameters of exchangers

For hydraulic parameters of exchangers see the page 48.

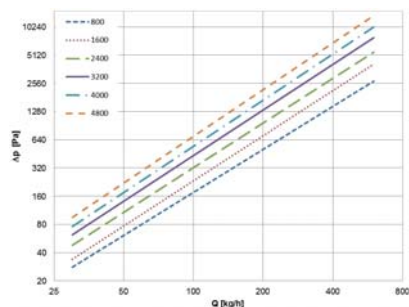

Fans input power [W]

Length [mm]	Speed [-] / Fans input power [W]				
	0	1	2	3	4 max
700	-	1 W	2 W	3 W	5 W
1000	-	2 W	3 W	6 W	9 W
1200	-	2 W	3 W	6 W	9 W
1400	-	3 W	6 W	10 W	17 W
1600	-	3 W	5 W	10 W	14 W
1800	-	4 W	6 W	12 W	17 W
2000	-	4 W	6 W	12 W	17 W
2200	-	4 W	7 W	13 W	18 W
2400	-	5 W	9 W	16 W	25 W
2600	-	6 W	11 W	20 W	33 W

* Approximate fan input powers /When using electrothermal actuator add in the convector's power 3 W

LST Fan-operated wall-mounted convector heaters

Fan-operated wall-mounted heaters are distinctive for their compact appearance. The electrothermal actuator for heating fluid flow control, as well as the water connection piping, is concealed inside the heater unit. The installed 24V DC fan effectively balances out extreme temperature variations experienced during winter by supplying a sufficient heat output, promptly responding to changes in temperature and securing high heat outputs even when operated in low-temperature heating systems.

The cover is available in a range of RAL colours, but also in metallic options. Individual component colours can be combined (grille, side panel, front panel).

- Shopping malls, car showrooms, airport lounges
- Offices, administrative buildings
- Hotels
- Entrance areas, lobbies



Standard Equipment

Cover	surface-treated steel sheet metal with an epoxy polyester powder coating
Grille	round or rectangular holes as per order specifications; the linear grille is securely attached to the cover
Heat-exchanger	black painted Al-Cu lamellar heat-exchanger with an air vent valve, 2 × G1/2" inner threads
Fan	Modern tangential fan with 24 V DC EC motor with high efficiency, rotors protection
Valve	corner thermostatic valve, M30 x 1.5 thread with a 2.5 mm pitch
Mounting	wall brackets with connecting elements

Operating Conditions

Max. operating temp.	110°C
Max. operating excess pressure	1 MPa (10 bar)
Protection	IP20
Ambient conditions	temperature T = +2 to +40°C humidity Rh = 20 to 70%
Operating voltage	24 V DC

Convactor Heater Options and Size Variations

Standard valve connection V

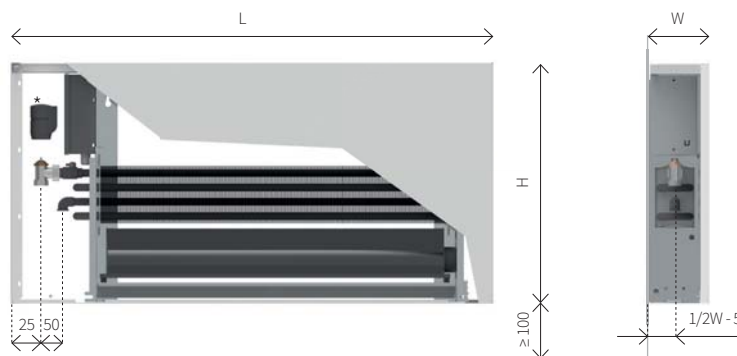

* electrothermal actuator not supplied with the heater

Convactor heater size variations

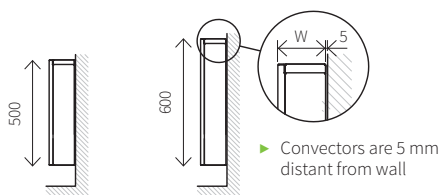

Height H [mm]	500	600
Width W [mm]	122	122
	182	182
Length L [mm]	700-1 600	700-1 600

Energy saving



Fan convectors operate on safe voltage of 24 V DC. The fan motors have very low consumption of electric power. The speed of fans is continuously commanded by controlling voltage of 0...10 V DC.

Component parts of the convector heater

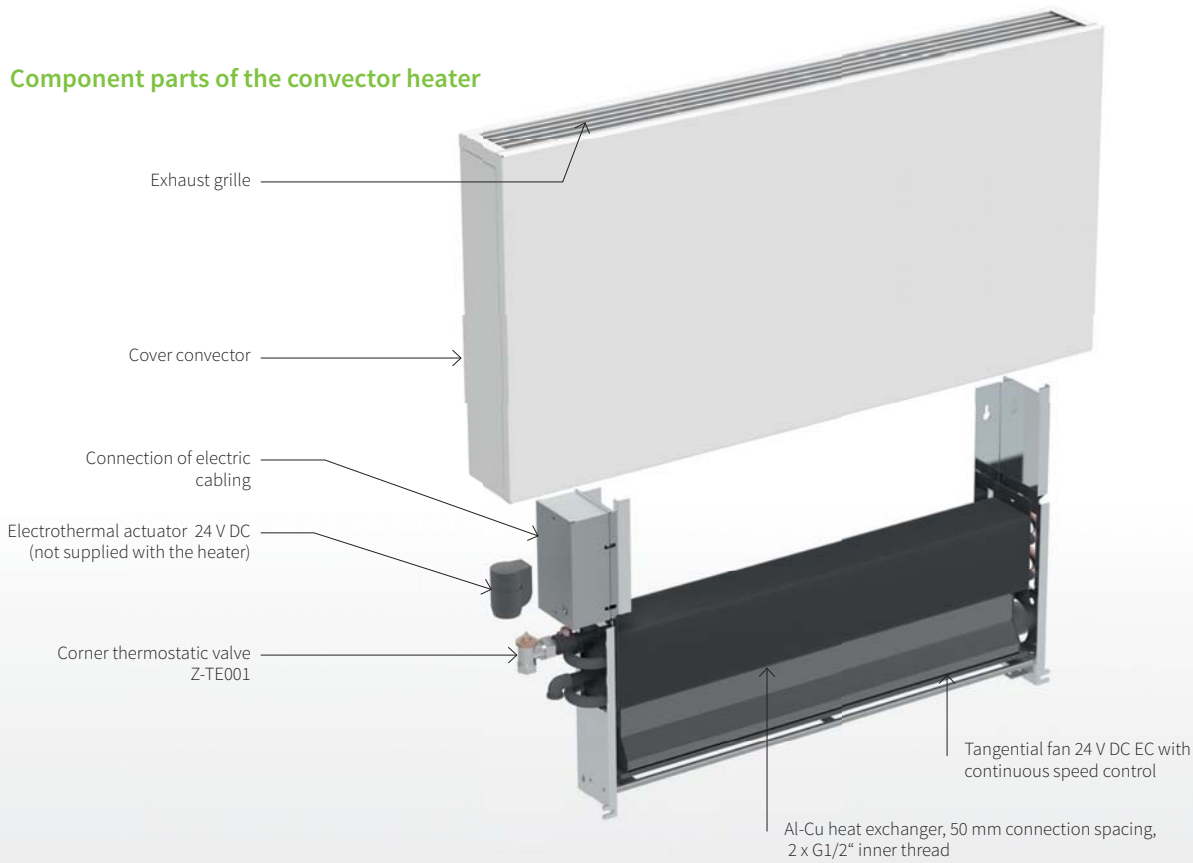

Accessories



► Details of accessories on the page 8

Grilles



Grille R
- rectangular holes

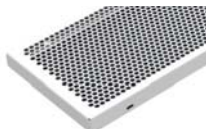

Grille C
- round holes



Grille L
- linear grille

tip Order grilles and stands in colours that vary from the cover to brighten up your interior

► Options and grille details, page 5

Brackets

W brackets

Wall brackets for attaching heat exchanger and convector cover are parts of the convector.



Number of brackets as per the body length

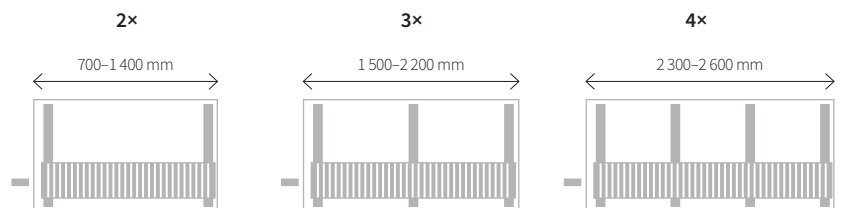

Coding

LST	0500	0182	1200	C	01	R	1	V	L	W	
Model	Height H	Width W	Length L	Material	Colour	Grille	Grille colour	Connection type	Connection side	Brackets	Atypical
LST	0500 mm 0600 mm	0122 mm 0182 mm	0700 1000 1200 1400 1600	C Sheet steel with surface finish and an epoxy polyester powder coating	As per RAL colour chart Structured colours Metallic paint colours See colour chart, page 57	R rectangular holes C round holes L linear grille	1 Same as cover colour 9 Grille in different colour	V With corner thermostatic valve, bottom connection, 50 mm spacing	L Left side R Right side	W brackets for wall mounting	Empty position for standard A In non-standard heater configurations

► Other options, see page 59

← **Height 500 mm / Width 122 mm** →

75/65/20°C	Speed [-] / Heating output [W]				
Length [mm]	0	1	2	3	4 max
700	274	658	898	1 137	1 305
1000	452	1 325	1 810	2 291	2 629
1200	572	1 741	2 378	3 010	3 455
1400	691	2 128	2 907	3 679	4 222
1600	810	2 399	3 277	4 147	4 760

55/45/20°C	Speed [-] / Heating output [W]				
Length [mm]	0	1	2	3	4 max
700	158	379	518	655	752
1000	261	764	1 043	1 320	1 515
1200	329	1 003	1 370	1 734	1 991
1400	398	1 226	1 675	2 120	2 433
1600	467	1 382	1 888	2 390	2 743

Exponent n = 1,079

← **Height 500 mm / Width 182 mm** →

75/65/20°C	Speed [-] / Heating output [W]				
Length [mm]	0	1	2	3	4 max
700	474	815	1 101	1 359	1 558
1000	782	1 641	2 218	2 738	3 139
1200	988	2 156	2 914	3 598	4 125
1400	1 194	2 635	3 561	4 397	5 041
1600	1 400	2 971	4 015	4 957	5 683

55/45/20°C	Speed [-] / Heating output [W]				
Length [mm]	0	1	2	3	4 max
700	272	468	633	782	896
1000	450	944	1 275	1 575	1 805
1200	568	1 240	1 676	2 069	2 372
1400	687	1 515	2 048	2 529	2 899
1600	805	1 708	2 309	2 851	3 268

Exponent n = 1,083

← **Height 600 mm / Width 122 mm** →

75/65/20°C	Speed [-] / Heating output [W]				
Length [mm]	0	1	2	3	4 max
700	305	724	956	1 182	1 335
1000	505	1 459	1 926	2 382	2 690
1200	637	1 917	2 530	3 130	3 535
1400	770	2 343	3 092	3 825	4 320
1600	903	2 641	3 486	4 312	4 870

55/45/20°C	Speed [-] / Heating output [W]				
Length [mm]	0	1	2	3	4 max
700	175	414	546	676	763
1000	288	834	1 101	1 361	1 538
1200	364	1 096	1 446	1 789	2 020
1400	440	1 339	1 768	2 186	2 469
1600	516	1 510	1 993	2 465	2 784

Exponent n = 1,095

← **Height 600 mm / Width 182 mm** →

75/65/20°C	Speed [-] / Heating output [W]				
Length [mm]	0	1	2	3	4 max
700	484	897	1 171	1 413	1 594
1000	800	1 807	2 359	2 847	3 212
1200	1 011	2 374	3 100	3 741	4 220
1400	1 222	2 901	3 789	4 572	5 158
1600	1 432	3 271	4 271	5 154	5 815

55/45/20°C	Speed [-] / Heating output [W]				
Length [mm]	0	1	2	3	4 max
700	275	510	666	804	907
1000	455	1 027	1 342	1 619	1 827
1200	575	1 350	1 763	2 127	2 400
1400	695	1 650	2 155	2 600	2 933
1600	814	1 860	2 429	2 931	3 307

Exponent n = 1,105

LST - Heating output recalculation for another temperature gradient

To obtain the heating output for a different temperature gradient multiply heating output value at 75/65/20 °C by the below mentioned factor **f**.

Example

Heating output of the convector LST 0500 0182 1400 for temperature gradient 70/55°C

1. Output 75/65/20 °C = 3 561 W
2. Factor from the table for 70/55/20 °C at 182 width: f = 0,839
3. Output 70/55/20 °C = f x 3561 = 2 988 W

Height [mm]	90/70 °C	82/71 °C	70/55 °C	70/50°C	50/40 °C
0500 0122	1,217	1,141	0,839	0,768	0,466
0500 0182	1,218	1,142	0,839	0,767	0,465
0600 0122	1,221	1,143	0,837	0,765	0,461
0600 0182	1,223	1,145	0,836	0,763	0,458

Room temperature 20 °C

Heating water flow rate through exchanger

To reach the required heating output we determine the desired flow of heating water through the convector exchanger. We calculate it from heating output of the convector for the selected input and output temperatures of heating water.

$$M = 0,86 * Q / (T1-T2) \text{ [kg / h]}$$

M [kg/h] mass rate of flow, heating water flowing through exchanger

Q [W] convector heating output

T1-T2 [°C] difference between input and output temperature

0,86 invariable for recalculation of units

Acoustic pressure [dB(A)]

Length [mm]	Speed [-] / Acoustic pressure [dB(A)]				
	0	1	2	3	4 max
700	-	<20	27	37	45
1000	-	22	30	40	45
1200	-	22	31	41	45
1400	-	22	31	41	45
1600	-	23	32	42	46

Recalculation to other temperature gradients

Convector heating output reckoning follows by recalculation of the standardized output Q_n 75/65/20 °C

$$Q = Q_n * \Psi * (\Delta T / 50)^n \text{ [W]; where } \Delta T = ((T1+T2)/2) - T_i \text{ [°C]}$$

Q_n [W] heating output for temperature gradient

Ψ [-] mass rate of flow coefficient (for current flow rate $\Psi = 1$)

T1 [°C] input water temperature

T2 [°C] output water temperature

Ti [°C] temperature in the room

n [-] temperature exponent

Table of hydraulic parameters of exchangers

For hydraulic parameters of exchangers see the page 50.

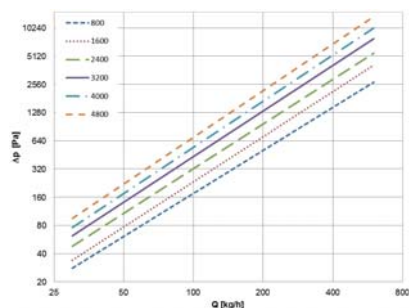

Fans input power [W]

Length [mm]	Speed [-] / Fans input power [W]				
	0	1	2	3	4 max
700	-	1 W	2 W	3 W	5 W
1000	-	2 W	3 W	6 W	9 W
1200	-	2 W	3 W	6 W	9 W
1400	-	3 W	6 W	10 W	17 W
1600	-	3 W	5 W	10 W	14 W

* Approximate fan input powers /When using electrothermal actuator add in the convector's power 3 W

ECOLITE ROUND

Self-standing and Wall-mounted Convactor Heaters

New series of convectors with rounded edges. Their elegant look can be used in both modern and historic buildings but also where its rounded shape provides a prevention of injury: nurseries, schools and health facilities.



◀ TZK 0200 0198 1200



◀ TZK 0200 0198 1200



◀ TST 0500 0122 1000



◀ TZT 0350 0138 1000

TZK Self-standing convector heaters

Convector heaters with lamellar heat-exchangers are popular for their simple design. The rounding not only enhances the aesthetic appearance of the units, but it also improves safety in exposed areas. They are often installed in schools, preschools, and health and social facilities where injury prevention and hygiene requirements are more stringent.

A range of grille options and stands for floor mounting allows the designer to perfectly match the heater to the interior.

- Schools, preschools
- Hospitals, retirement homes
- Institutions for people with reduced mobility
- Family houses
- Shopping malls, airport lounges
- Hotels
- Entrance areas, lobbies



The surface temperature of the heater cover never exceeds **43°C MAX**



Operating Conditions

Max. operating temp.	110°C
Max. operating excess pressure	1 MPa (10 bar)
Protection	IP20
Ambient conditions	temperature T = +2 to +40°C humidity Rh = 20 to 70%

Standard Equipment

Cover	surface-treated steel sheet metal with an epoxy polyester powder coating
Grille	round or rectangular holes as per order specifications; grille is securely attached to the cover
Heat-exchanger	Al-Cu lamellar heat-exchanger with a air vent valve, 2 × G1/2" inner connection threads
Valve	axial thermostatic valve, M30 x 1.5 thread with a 2.5 mm pitch (not supplied with side connection configuration)
Mounting	floor anchor stands as per order specifications

Convector Heater Options and Size Variations

Standard valve connection V

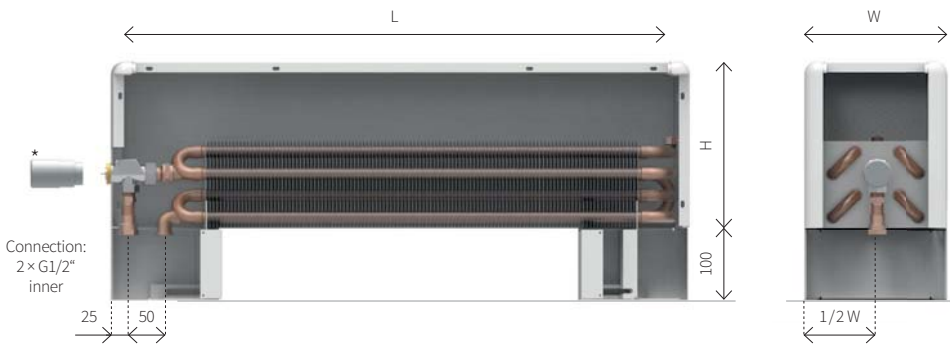

* thermostatic head not supplied with the heater

Side connection B

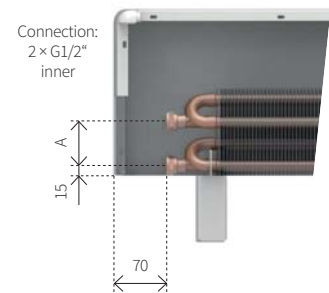

H [mm]	A [mm]
90	30
150-600	60

Convector heater size variations

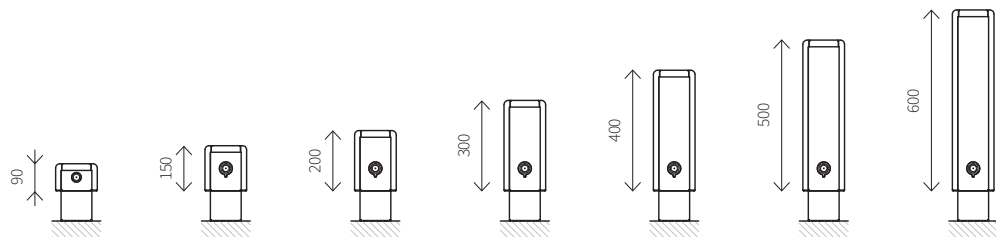

Height H [mm]	90	150	200	300	400	500	600
Width W [mm]	138	138	138	138	138	138	138
Length L [mm]	198	198	198	198	198	198	198
	258	258	258	258	258	258	258
Length L [mm]	400-2800	400-2800	400-2800	400-2800	400-2800	400-2800	400-2800

Component parts of the convector heater

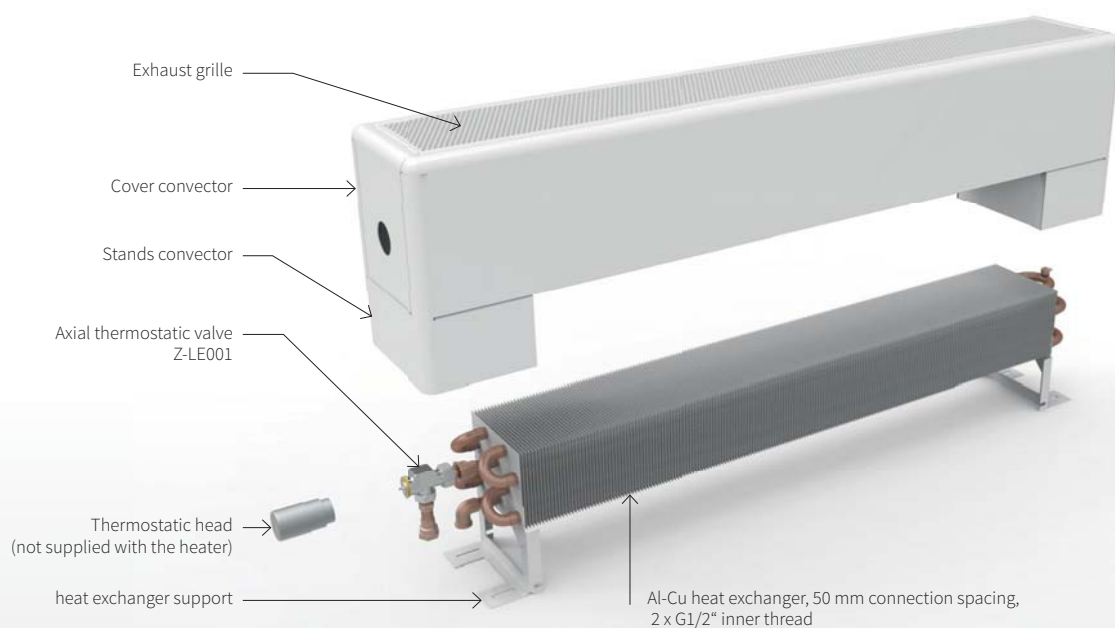

Accessories



► Details of accessories on the page 6

Grilles



Grille R
- rectangular holes



Grille C
- round holes

tip Order grilles and stands in colours that vary from the cover to brighten up your interior

► Colour design options and grille details, page 5

Stands



Stand K
- floor mounting
- inconspicuous
- height 100 mm



Stand S
- self-standing model
- cover water piping
- height 100 mm
(cannot be used for B connection)



Stand H
- subfloor mounting
- option of plastic cap
- height to order

Number of stands as per the body length

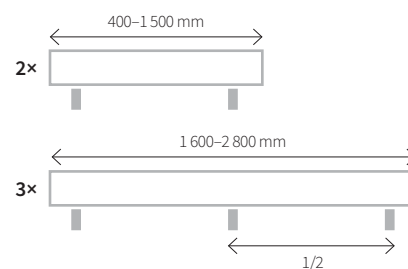

Coding

TZK	0150	0138	0400	C	01	R	1	V	L	K	
Model	Height H	Width W	Length L	Material	Colour	Grille	Grille colour	Connection type	Connection side	Stands	Atypical
TZK	0090 mm 0150 mm 0200 mm 0300 mm 0400 mm 0500 mm 0600 mm	0138 mm 0198 mm 0258 mm	0400 mm 0500 mm ... 1200 mm 1400 mm ... 2800 mm	C Sheet steel with surface finish and an epoxy polyester powder coating	As per RAL colour chart Structured colours Metallic paint colours See colour chart, page 57	R rectangular holes C round holes	1 Same as cover colour 9 Grille in different colour	V With axial thermostatic valve, bottom connection, 50 mm spacing B Side connection, 60 mm spacing, valve not included in the delivery	L Left side R Right side	K Inconspicuous, subtle S Water piping cover H Subfloor mounting	Empty position for standard A In non-standard heater configurations

► Other options, see page 59

TZK - Self-standing convectors heating output

Width 138 mm

75/65/20°C	Height [mm] / Heating output [W]						
Length [mm]	90	150	200	300	400	500	600
400	113	179	196	221	241	258	272
500	161	235	256	290	316	338	357
600	209	314	342	386	421	450	476
700	256	381	415	469	511	547	578
800	304	448	488	552	601	643	679
900	352	515	561	634	692	740	781
1000	400	582	635	717	782	836	883
1100	447	649	708	799	872	932	985
1200	495	716	781	882	962	1029	1087
1400	590	850	927	1047	1142	1221	1290
1600	702	1007	1098	1240	1353	1446	1528
1800	797	1141	1244	1406	1533	1639	1732
2000	893	1275	1391	1571	1713	1832	1935
2200	988	1409	1537	1736	1893	2025	2139
2400	1083	1544	1683	1901	2073	2217	2342
2600	1179	1678	1829	2067	2254	2410	2546
2800	1274	1812	1976	2232	2434	2603	2749
Exponent n [-]	1,42	1,42	1,42	1,42	1,42	1,42	1,42

55/45/20°C	Height [mm] / Heating output [W]						
Length [mm]	90	150	200	300	400	500	600
400	55	87	95	107	117	125	132
500	78	114	124	140	153	164	173
600	101	152	166	187	204	218	230
700	124	184	201	227	248	265	280
800	147	217	236	267	291	311	329
900	170	249	272	307	335	358	378
1000	193	282	307	347	378	405	427
1100	217	314	343	387	422	451	477
1200	240	347	378	427	466	498	526
1400	286	412	449	507	553	591	624
1600	340	487	531	600	655	700	740
1800	386	552	602	680	742	793	838
2000	432	617	673	760	829	887	937
2200	478	682	744	840	916	980	1035
2400	525	747	815	920	1004	1073	1134
2600	571	812	885	1000	1091	1166	1232
2800	617	877	956	1080	1178	1260	1331
Exponent n [-]	1,42	1,42	1,42	1,42	1,42	1,42	1,42

Width 198 mm

75/65/20°C	Height [mm] / Heating output [W]						
Length [mm]	90	150	200	300	400	500	600
400	191	293	320	363	397	426	450
500	271	384	419	476	520	558	590
600	352	511	559	634	694	744	787
700	432	621	679	770	842	903	955
800	513	730	799	906	991	1062	1124
900	593	840	918	1042	1139	1221	1292
1000	673	949	1038	1177	1287	1380	1461
1100	754	1058	1157	1313	1436	1539	1629
1200	834	1168	1277	1449	1584	1698	1797
1400	995	1386	1516	1720	1881	2016	2134
1600	1183	1642	1796	2037	2228	2388	2527
1800	1344	1861	2035	2309	2525	2706	2864
2000	1504	2080	2274	2580	2822	3024	3201
2200	1665	2298	2514	2852	3118	3343	3538
2400	1826	2517	2753	3123	3415	3661	3874
2600	1987	2736	2992	3394	3712	3979	4211
2800	2148	2955	3231	3666	4009	4297	4548
Exponent n [-]	1,42	1,43	1,43	1,43	1,43	1,43	1,43

55/45/20°C	Height [mm] / Heating output [W]						
Length [mm]	90	150	200	300	400	500	600
400	93	141	154	175	191	205	217
500	132	185	202	229	251	269	285
600	170	247	270	306	335	359	380
700	209	299	327	371	406	435	461
800	248	352	385	437	478	512	542
900	287	405	443	502	549	589	623
1000	326	458	500	568	621	665	704
1100	365	510	558	633	692	742	785
1200	404	563	616	698	764	819	867
1400	482	668	731	829	907	972	1029
1600	573	792	866	982	1074	1151	1219
1800	651	897	981	1113	1217	1305	1381
2000	729	1003	1097	1244	1360	1458	1543
2200	807	1108	1212	1375	1504	1612	1706
2400	885	1214	1327	1506	1647	1765	1868
2600	963	1319	1443	1637	1790	1918	2030
2800	1041	1424,6	1557,9	1767,3	1933	2072	2193
Exponent n [-]	1,42	1,43	1,43	1,43	1,43	1,43	1,43

Width 258 mm

75/65/20°C	Height [mm] / Heating output [W]						
Length [mm]	90	150	200	300	400	500	600
400	266	414	448	501	543	577	607
500	377	543	587	657	711	757	796
600	489	723	783	876	949	1009	1061
700	601	878	951	1063	1151	1225	1288
800	713	1033	1118	1251	1354	1440	1515
900	825	1188	1286	1438	1557	1656	1742
1000	937	1342	1453	1626	1760	1872	1969
1100	1048	1497	1621	1813	1963	2088	2196
1200	1160	1652	1788	2000	2166	2303	2422
1400	1384	1961	2124	2375	2572	2735	2876
1600	1645	2323	2515	2813	3046	3239	3407
1800	1869	2632	2850	3188	3452	3671	3861
2000	2093	2942	3185	3563	3857	4103	4314
2200	2316	3251	3520	3937	4263	4534	4768
2400	2540	3561	3855	4312	4669	4966	5222
2600	2764	3870	4190	4687	5075	5397	5676
2800	2987	4180	4526	5062	5480	5829	6130
Exponent n [-]	1,42	1,45	1,45	1,45	1,45	1,45	1,45

55/45/20°C	Height [mm] / Heating output [W]						
Length [mm]	90	150	200	300	400	500	600
400	129	197	214	239	259	275	289
500	183	259	280	313	339	361	379
600	237	345	373	418	452	481	506
700	291	419	453	507	549	584	614
800	345	492	533	596	646	687	722
900	399	566	613	686	742	790	830
1000	453	640	693	775	839	892	939
1100	507	714	773	864	936	995	1047
1200	561	788	853	954	1033	1098	1155
1400	670	935	1012	1132	1226	1304	1371
1600	796	1108	1199	1341	1452	1544	1624
1800	904	1255	1359	1520	1646	1750	1841
2000	1013	1403	1519	1699	1839	1956	2057
2200	1121	1550	1678	1877	2033	2162	2273
2400	1229	1698	1838	2056	2226	2367	2490
2600	1337	1845	1998	2235	2419	2573	2706
2800	1446	1993	2158	2413	2613	2779	2922
Exponent n [-]	1,42	1,45	1,45	1,45	1,45	1,45	1,45

TZK - Heating output recalculation for another temperature gradient

To obtain the heating output for a different temperature gradient multiply heating output value at 75/65/20 °C by the below mentioned factor **f**.

Example

Heating output of the convector TZK 0200 0138 2000 for temperature gradient 70/55°C

1. Output 75/65/20 °C = 1 391 W
2. Factor from the table for 70/55/20 °C at 138 width: f = 0.794
3. Output 70/55/20 °C = f × 1391 = 1 104 W

Width 138 mm					
Height [mm]	90/70 °C	82/71 °C	70/55 °C	70/50°C	50/40 °C
90	1,295	1,190	0,794	0,707	0,367
150	1,295	1,190	0,794	0,707	0,367
200	1,295	1,190	0,794	0,707	0,367
300	1,295	1,190	0,794	0,707	0,367
400	1,295	1,190	0,794	0,707	0,367
500	1,295	1,190	0,794	0,707	0,367
600	1,295	1,190	0,794	0,707	0,367

Room temperature 20 °C

Width 198 mm					
Height [mm]	90/70 °C	82/71 °C	70/55 °C	70/50°C	50/40 °C
90	1,295	1,190	0,794	0,707	0,367
150	1,303	1,194	0,790	0,701	0,359
200	1,303	1,194	0,790	0,701	0,359
300	1,303	1,194	0,790	0,701	0,359
400	1,303	1,194	0,790	0,701	0,359
500	1,303	1,194	0,790	0,701	0,359
600	1,303	1,194	0,790	0,701	0,359

Room temperature 20 °C

Width 258 mm					
Height [mm]	90/70 °C	82/71 °C	70/55 °C	70/50°C	50/40 °C
90	1,295	1,190	0,794	0,707	0,367
150	1,298	1,191	0,793	0,705	0,364
200	1,298	1,191	0,793	0,705	0,364
300	1,298	1,191	0,793	0,705	0,364
400	1,298	1,191	0,793	0,705	0,364
500	1,298	1,191	0,793	0,705	0,364
600	1,298	1,191	0,793	0,705	0,364

Room temperature 20 °C

Recalculation to other temperature gradients

Convector heating output reckoning follows by recalculation of the standardized output Q_n 75/65/20 °C

$$Q = Q_n \cdot \Psi \cdot (\Delta T / 50)^n \text{ [W]; where } \Delta T = ((T_1 + T_2) / 2) - T_i \text{ [}^\circ\text{C]}$$

- Q_n [W] heating output for temperature gradient
- Ψ [-] mass rate of flow coefficient (for current flow rate $\Psi = 1$)
- T_1 [°C] input water temperature
- T_2 [°C] output water temperature
- T_i [°C] temperature in the room
- n [-] temperature exponent

Heating water flow rate through exchanger

To reach the required heating output we determine the desired flow of heating water through the convector exchanger. We calculate it from heating output of the convector for the selected input and output temperatures of heating water.

$$M = 0,86 \cdot Q / (T_1 - T_2) \text{ [kg / h]}$$

- M [kg/h] mass rate of flow, heating water flowing through exchanger
- Q [W] convector heating output
- $T_1 - T_2$ [°C] difference between input and output temperature
- 0,86** invariable for recalculation of units

Table of hydraulic parameters of exchangers

For hydraulic parameters of exchangers see the page 48.

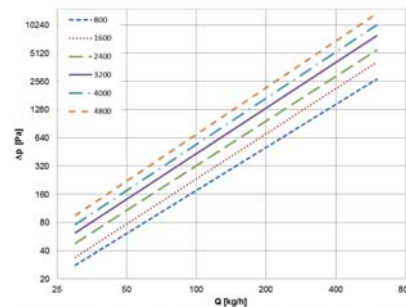

TSK Wall-mounted convector heaters

Wall-mounted convector heaters with smooth front panelling and rounded edges will prove an excellent addition to both modern and historic interiors as well as to environments with increased safety requirements.

Convection heating is especially suitable for settings where prompt response to temperature fluctuations and low surface temperature are required. For a clean look, select a heater-to-wall connection option.

- Schools, preschools
- Hospitals, retirement homes
- Institutions for people with reduced mobility
- Family houses
- Entrance areas, lobbies
- Shopping malls, airport lounges
- Hotels



The surface temperature of the heater cover never exceeds **43°C MAX**



Standard Equipment

Cover	surface-treated steel sheet metal with an epoxy polyester powder coating
Grille	round or rectangular holes as per order specifications; grille is securely attached to the cover
Heat-exchanger	Al-Cu lamellar heat-exchanger with a air vent valve, 2 x G1/2" inner connection threads
Valve	axial thermostatic valve, M30 x 1.5 thread with a 2.5 mm pitch (not supplied with side connection configuration)
Mounting	wall brackets with connecting elements

Operating Conditions

Max. operating temp.	110°C
Max. operating excess pressure	1 MPa (10 bar)
Protection	IP20
Ambient conditions	temperature T = +2 to +40°C humidity Rh = 20 to 70%

Convactor Heater Options and Size Variations

Standard valve connection V

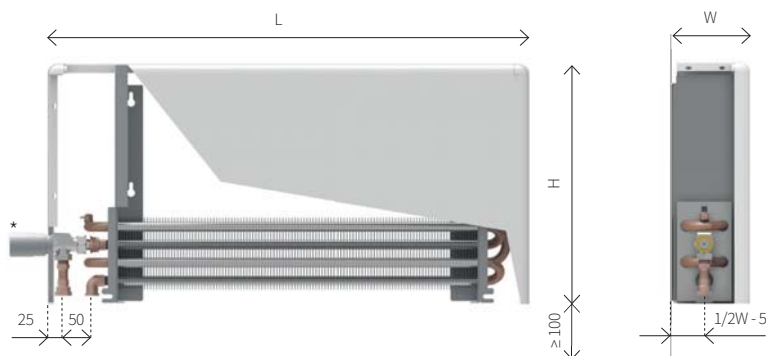

* thermostatic head not supplied with the heater
** not available for W = 82 mm

Convactor heater size variations

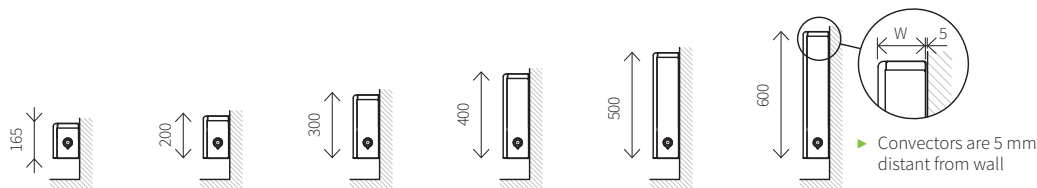

H [mm]	W = 82 mm		W ≥ 122 mm	
	A [mm]	B [mm]	A [mm]	B [mm]
165	-	-	60	40
200, 300	60	80	60	40
400, 500, 600	180	80	60	40

Height H [mm]	165	200	300	400	500	600
Width W [mm]	122	122	122	122	122	122
Length L [mm]	400-2800	400-2800	400-2800	400-2800	400-2800	400-2800

Component parts of the convector heater

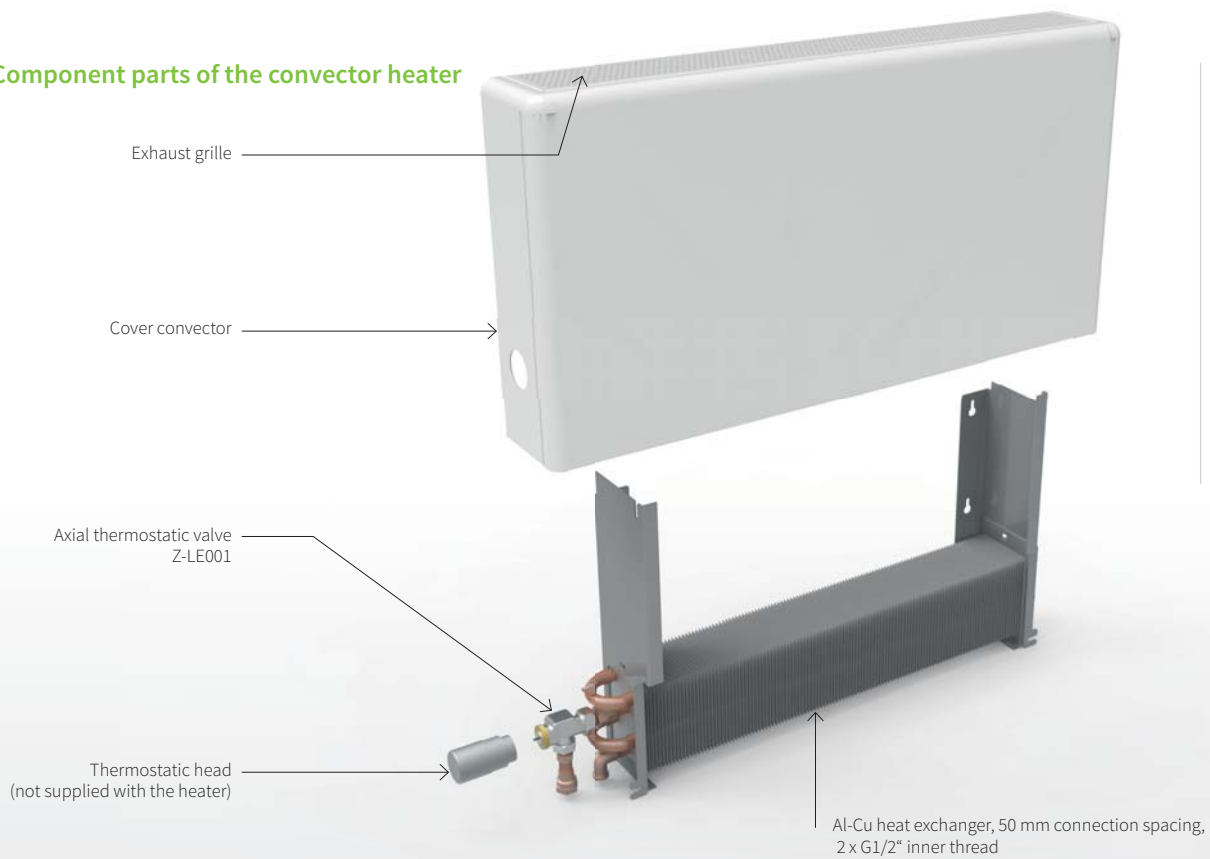

Accessories



► Details of accessories on the page 6

Grilles



Grille R
- rectangular holes

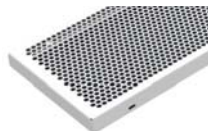

Grille C
- round holes

tip Order grilles and stands in colours that vary from the cover to brighten up your interior

► Options and grille details, page 5

Brackets

W brackets

Wall brackets for attaching heat exchanger and convector cover are parts of the convector.



Number of brackets as per the body length

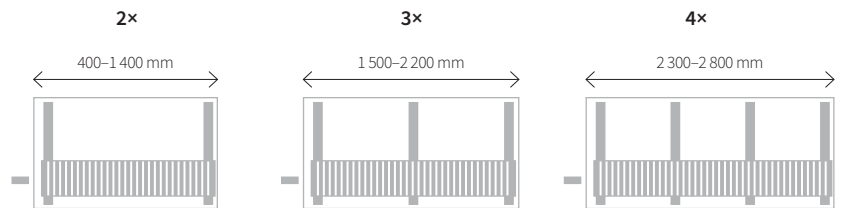

Coding

TSK	0300	0182	1200	C	01	R	1	V	L	W	
Model	Height H	Width W	Length L	Material	Colour	Grille	Grille colour	Connection type	Connection side	Brackets	Atypical
TSK	0165 mm 0200 mm 0300 mm 0400 mm 0500 mm 0600 mm	0082 mm 0182 mm 0242 mm	0400 mm 0500 mm ... 1200 mm 1400 mm ... 2800 mm	C Sheet steel with surface finish and an epoxy polyester powder coating	As per RAL colour chart Structured colours Metallic paint colours See colour chart, page 57	R rectangular holes C round holes	1 Same as cover colour 9 Grille in different colour	V With valve, bottom connection B Side connection Y With valve, connection to the wall (n/a for W=82 mm) Z connection to the wall without a hole in the cover (n/a for W=82 mm)	L Left side R Right side	W brackets for wall mounting	Empty position for standard A In non-standard heater configurations

► Other options, see page 59

TSK - Wall-mounted convectors heating output

Width 82 mm

75/65/20°C	Height [mm] / Heating output [W]				
Length [mm]	200	300	400	500	600
400	87	105	125	139	150
500	130	158	188	208	225
600	174	210	251	277	300
700	217	262	313	346	375
800	261	315	376	415	450
900	304	367	439	485	525
1000	348	420	501	554	600
1100	391	472	564	623	675
1200	434	525	627	692	750
1400	521	630	752	831	899
1600	608	735	877	969	1049
1800	695	840	1003	1108	1199
2000	782	945	1128	1246	1349
2200	869	1050	1253	1385	1499
2400	956	1155	1379	1523	1649
2600	1043	1260	1504	1662	1799
2800	1129	1365	1629	1800	1949
Exponent n [-]	1,45	1,43	1,41	1,41	1,40

55/45/20°C	Height [mm] / Heating output [W]				
Length [mm]	200	300	400	500	600
400	41	51	61	68	73
500	62	76	92	101	110
600	83	101	122	135	146
700	104	127	153	169	183
800	124	152	183	203	220
900	145	177	214	236	256
1000	166	202	244	270	293
1100	187	228	274	304	329
1200	207	253	305	337	366
1400	249	304	366	405	439
1600	290	354	427	472	512
1800	332	405	488	540	585
2000	373	456	549	607	659
2200	414	506	610	675	732
2400	456	557	671	742	805
2600	497	607	732	810	878
2800	539	658	793	877	951
Exponent n [-]	1,45	1,43	1,41	1,41	1,40

Width 122 mm

75/65/20°C	Height [mm] / Heating output [W]					
Length [mm]	165	200	300	400	500	600
400	127	137	163	186	207	228
500	190	206	244	279	311	342
600	254	274	326	372	415	456
700	317	343	407	465	518	570
800	381	411	489	558	622	684
900	444	480	570	650	726	798
1000	507	548	652	743	829	912
1100	571	617	733	836	933	1026
1200	634	686	815	929	1036	1140
1400	761	823	977	1115	1244	1368
1600	888	960	1140	1301	1451	1596
1800	1015	1097	1303	1487	1658	1824
2000	1141	1234	1466	1672	1866	2052
2200	1268	1371	1629	1858	2073	2280
2400	1395	1508	1792	2044	2280	2508
2600	1522	1645	1955	2230	2487	2736
2800	1649	1782	2118	2416	2695	2963
Exponent n [-]	1,4	1,4	1,41	1,42	1,43	1,43

55/45/20°C	Height [mm] / Heating output [W]					
Length [mm]	165	200	300	400	500	600
400	62	67	79	90	100	110
500	93	101	119	135	150	164
600	124	134	159	180	200	219
700	155	168	198	225	250	274
800	186	201	238	270	300	329
900	217	235	278	315	350	384
1000	248	268	317	360	400	438
1100	279	302	357	405	450	493
1200	310	335	397	450	500	548
1400	373	402	476	541	600	658
1600	435	469	555	631	700	767
1800	497	536	634	721	801	877
2000	559	603	714	811	901	986
2200	621	670	793	901	1001	1096
2400	683	737	872	991	1101	1206
2600	745	804	952	1081	1201	1315
2800	807	871	1031	1171	1301	1425
Exponent n [-]	1,4	1,4	1,41	1,42	1,43	1,43

Width 182 mm

75/65/20°C	Height [mm] / Heating output [W]					
Length [mm]	165	200	300	400	500	600
400	215	232	276	318	359	401
500	322	348	415	477	539	601
600	429	464	553	636	718	801
700	537	580	691	795	898	1002
800	644	695	829	954	1078	1202
900	752	811	967	1113	1257	1402
1000	859	927	1105	1272	1437	1603
1100	966	1043	1244	1432	1616	1803
1200	1074	1159	1382	1591	1796	2003
1400	1288	1391	1658	1909	2155	2404
1600	1503	1623	1935	2227	2514	2805
1800	1718	1854	2211	2545	2874	3205
2000	1932	2086	2487	2863	3233	3606
2200	2147	2318	2764	3181	3592	4007
2400	2362	2550	3040	3499	3951	4407
2600	2577	2782	3316	3817	4310	4808
2800	2791	3013	3593	4135	4669	5209
Exponent n [-]	1,4	1,4	1,41	1,43	1,44	1,46

55/45/20°C	Height [mm] / Heating output [W]					
Length [mm]	165	200	300	400	500	600
400	105	113	134	153	172	190
500	158	170	201	230	258	286
600	211	227	268	307	344	381
700	263	283	335	383	430	476
800	316	340	403	460	516	571
900	368	397	470	537	602	666
1000	421	453	537	613	688	761
1100	474	510	604	690	774	857
1200	526	567	671	767	859	952
1400	632	680	805	920	1031	1142
1600	737	793	939	1073	1203	1333
1800	842	907	1073	1227	1375	1523
2000	947	1020	1207	1380	1547	1713
2200	1052	1133	1342	1533	1719	1904
2400	1158	1247	1476	1687	1891	2094
2600	1263	1360	1610	1840	2063	2284
2800	1368	1473	1744	1993	2234	2475
Exponent n [-]	1,4	1,4	1,41	1,43	1,44	1,46

TSK - Wall-mounted convectors heating output

Width 242 mm

75/65/20°C	Height [mm] / Heating output [W]					
Length [mm]	165	200	300	400	500	600
400	316	333	384	444	512	590
500	474	499	577	666	767	884
600	632	665	769	887	1 023	1 179
700	790	831	961	1 109	1 279	1 474
800	947	998	1 153	1 331	1 535	1 769
900	1 105	1 164	1 346	1 553	1 791	2 064
1000	1 263	1 330	1 538	1 775	2 047	2 358
1100	1 421	1 496	1 730	1 997	2 302	2 653
1200	1 579	1 663	1 922	2 218	2 558	2 948
1400	1 895	1 995	2 307	2 662	3 070	3 538
1600	2 211	2 328	2 691	3 106	3 581	4 127
1800	2 526	2 660	3 075	3 550	4 093	4 717
2000	2 842	2 992	3 460	3 993	4 605	5 306
2200	3 158	3 325	3 844	4 437	5 116	5 896
2400	3 474	3 657	4 229	4 881	5 628	6 486
2600	3 790	3 990	4 613	5 324	6 139	7 075
2800	4 105	4 322	4 997	5 768	6 651	7 665
Exponent n [-]	1,39	1,4	1,43	1,47	1,5	1,54

55/45/20°C	Height [mm] / Heating output [W]					
Length [mm]	165	200	300	400	500	600
400	156	163	185	210	237	269
500	233	244	277	314	356	403
600	311	326	370	419	475	537
700	389	407	462	524	593	671
800	467	489	555	629	712	805
900	545	570	647	733	830	940
1000	623	651	739	838	949	1074
1100	700	733	832	943	1068	1208
1200	778	814	924	1048	1186	1342
1400	934	977	1109	1257	1423	1611
1600	1089	1140	1294	1467	1661	1879
1800	1245	1303	1479	1676	1 898	2 148
2000	1401	1465	1664	1886	2 135	2 416
2200	1556	1628	1849	2 095	2 372	2 685
2400	1712	1791	2033	2 305	2 610	2 953
2600	1868	1954	2218	2 514	2 847	3 222
2800	2023	2117	2403	2 724	3 084	3 490
Exponent n [-]	1,39	1,4	1,43	1,47	1,5	1,54

TSK - Heating output recalculation for another temperature gradient

To obtain the heating output for a different temperature gradient multiply heating output value at 75/65/20 °C by the below mentioned factor **f**.

Width 82 mm					
Height [mm]	90/70 °C	82/71 °C	70/55 °C	70/50°C	50/40 °C
200	1,303	1,194	0,790	0,701	0,359
300	1,298	1,191	0,793	0,705	0,364
400	1,293	1,188	0,795	0,708	0,369
500	1,293	1,188	0,795	0,708	0,369
600	1,291	1,187	0,797	0,710	0,372

Room temperature 20 °C

Width 122 mm					
Height [mm]	90/70 °C	82/71 °C	70/55 °C	70/50°C	50/40 °C
165	1,291	1,187	0,797	0,710	0,372
200	1,291	1,187	0,797	0,710	0,372
300	1,293	1,188	0,795	0,708	0,369
400	1,295	1,190	0,794	0,707	0,367
500	1,298	1,191	0,793	0,705	0,364
600	1,298	1,191	0,793	0,705	0,364

Room temperature 20 °C

Width 182 mm					
Height [mm]	90/70 °C	82/71 °C	70/55 °C	70/50°C	50/40 °C
165	1,291	1,187	0,797	0,710	0,372
200	1,291	1,187	0,797	0,710	0,372
300	1,293	1,188	0,795	0,708	0,369
400	1,298	1,191	0,793	0,705	0,364
500	1,300	1,192	0,791	0,703	0,361
600	1,305	1,195	0,789	0,700	0,356

Room temperature 20 °C

Width 242 mm					
Height [mm]	90/70 °C	82/71 °C	70/55 °C	70/50°C	50/40 °C
165	1,288	1,171	0,798	0,712	0,374
200	1,291	1,172	0,797	0,710	0,372
300	1,298	1,176	0,793	0,705	0,364
400	1,307	1,181	0,787	0,698	0,354
500	1,315	1,185	0,784	0,693	0,346
600	1,324	1,191	0,779	0,686	0,337

Room temperature 20 °C

Example

Heating output of the convector TSK 0200 0122 2000 for temperature gradient 70/55°C

1. Output 75/65/20 °C = 1234 W
2. Factor from the table for 70/55/20 °C at 122 width: f = 0.797
3. Output 70/55/20 °C = f x 1234 = 983 W

Table of hydraulic parameters of exchangers

For hydraulic parameters of exchangers see the page 50.

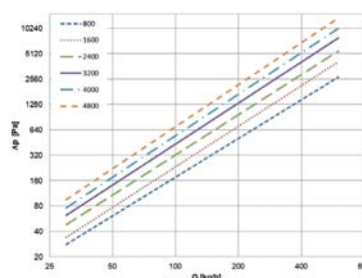

TZT Fan-operated self-standing convector heaters

Convector heaters equipped with a fan are suitable for low-temperature heating systems. Their heat output is sufficient even with low inlet temperatures of the heating fluid supplied by heat pumps. The rounding not only enhances the aesthetic appearance of the units, but it also improves safety in exposed areas. They are installed in schools, preschools and other buildings where increased safety is a concern.

The fan speed is continuously controlled by a thermostat, while the convector heater promptly responds to temperature variations in the room and ensures thermal comfort.

- Passive and low-energy houses
- Shopping malls, airport lounges
- Schools, preschools
- Hospitals, retirement homes
- Institutions for people with reduced mobility
- Hotels
- Entrance areas, lobbies

Standard Equipment

Cover	surface-treated steel sheet metal with an epoxy polyester powder coating
Grille	round or rectangular holes as per order specifications; grille is securely attached to the cover
Heat-exchanger	black painted Al-Cu lamellar heat-exchanger with an air vent valve, 2 × G1/2" inner threads
Fan	Modern tangential fan with 24 V DC EC motor with high efficiency, rotors protection
Valve	corner thermostatic valve, M30 x 1.5 thread with a 2.5 mm pitch
Mounting	floor anchor stands as per order specifications

Operating Conditions

Max. operating temp.	110°C
Max. operating excess pressure	1 MPa (10 bar)
Protection	IP20
Ambient conditions	temperature T = +2 to +40°C humidity Rh = 20 to 70%
Operating voltage	24 V DC



Convector Heater Options and Size Variations

Standard valve connection V



* electrothermal actuator not supplied with the heater

Convector heater size variations

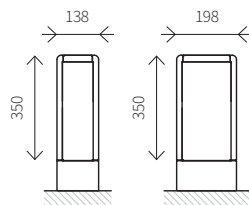

Height H [mm]	350
Width W [mm]	138 198
Length L [mm]	700-2600

Energy saving



Fan convectors operate on safe voltage of 24 V DC. The fan motors have very low consumption of electric power. The speed of fans is continuously commanded by controlling voltage of 0...10 V DC.

Component parts of the convector heater

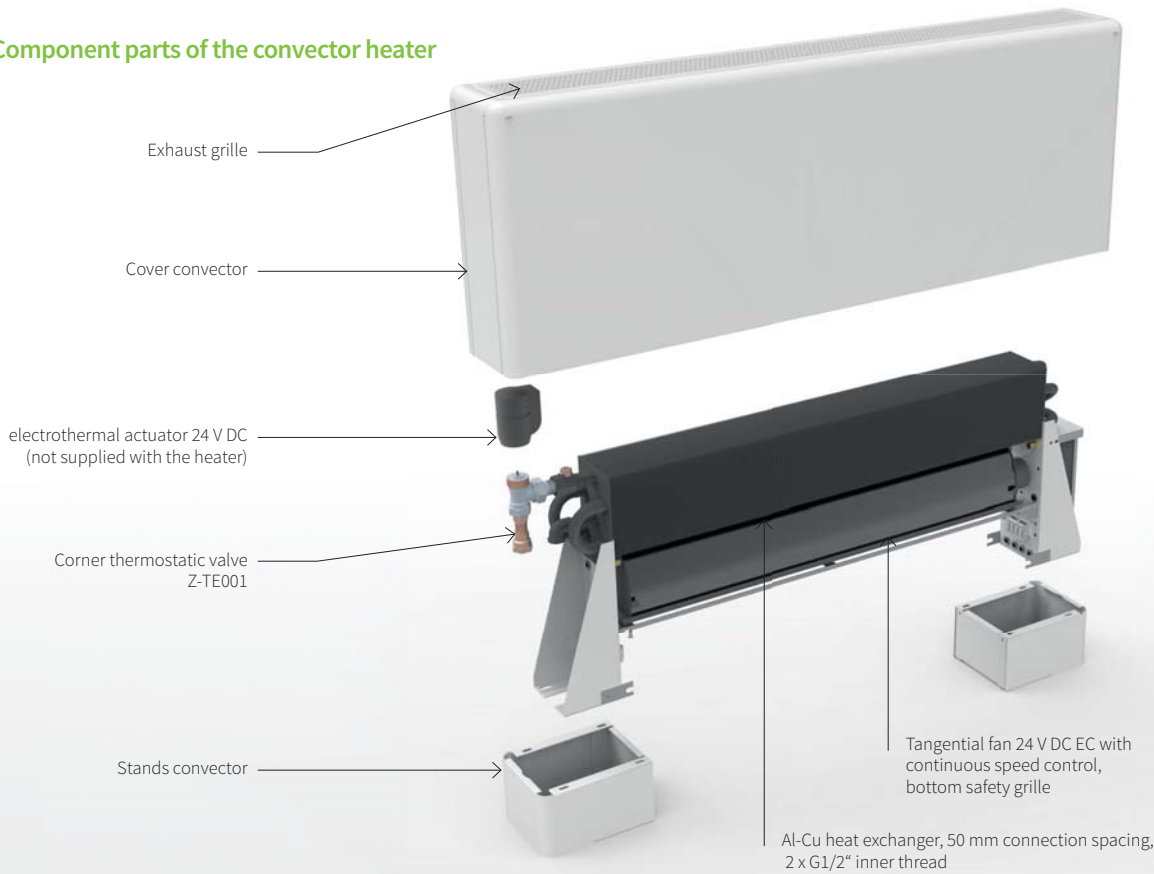

Accessories



► Details of accessories on the page 8

Grilles



Grille R
- rectangular holes

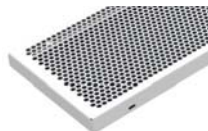

Grille C
- round holes

tip Order grilles and stands in colours that vary from the cover to brighten up your interior

► Colour design options and grille details, page 5

Stands



Stand S
- self-standing model
- cover water piping
- height 100 mm

Number of stands as per the body length

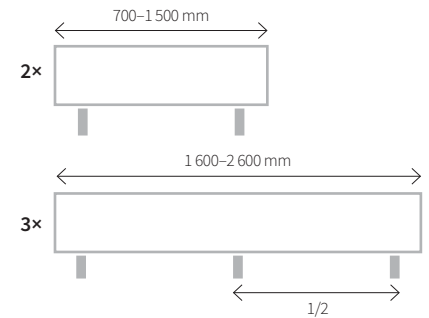

Coding

TZT	0350	0138	0400	C	01	R	1	V	L	S	
Model	Height H	Width W	Length L	Material	Colour	Grille	Grille colour	Connection type	Connection side	Stands	Atypical
TZT	0350 mm	0138 mm 0198 mm	700 mm 1 000 mm 1 200 mm ... 2 400 mm 2 600 mm	C Sheet steel with surface finish and an epoxy polyester powder coating	As per RAL colour chart Structured colours Metallic paint colours See colour chart, page 57	R rectangular holes C round holes	1 Same as cover colour 9 Grille in different colour	V With corner thermostatic valve, bottom connection, 50 mm spacing	L Left side R Right side	S water piping cover	Empty position for standard A In non-standard heater configurations

► Other options, see page 59

← **Width 138 mm** →

75/65/20°C	Speed [-] / Heating output [W]				
Length [mm]	0	1	2	3	4 max
700	243	685	912	1 144	1 313
1000	401	1 381	1 838	2 305	2 645
1200	507	1 814	2 415	3 028	3 475
1400	612	2 218	2 951	3 701	4 247
1600	718	2 500	3 327	4 173	4 788
1800	823	2 762	3 676	4 610	5 290
2000	929	3 195	4 252	5 333	6 120
2200	1 034	3 629	4 829	6 057	6 950
2400	1 140	4 032	5 366	6 730	7 723
2600	1 245	4 435	5 902	7 403	8 495

55/45/20°C	Speed [-] / Heating output [W]				
Length [mm]	0	1	2	3	4 max
700	141	398	529	664	762
1000	233	802	1 067	1 338	1 535
1200	294	1 053	1 401	1 758	2 017
1400	355	1 287	1 713	2 148	2 465
1600	416	1 451	1 931	2 422	2 779
1800	478	1 603	2 133	2 676	3 070
2000	539	1 855	2 468	3 096	3 552
2200	600	2 106	2 803	3 515	4 034
2400	661	2 340	3 114	3 906	4 482
2600	723	2 574	3 426	4 297	4 930

Exponent n = 1,065

← **Width 198 mm** →

75/65/20°C	Speed [-] / Heating output [W]				
Length [mm]	0	1	2	3	4 max
700	385	849	1 118	1 367	1 567
1000	636	1 710	2 252	2 755	3 158
1200	803	2 247	2 958	3 620	4 149
1400	971	2 746	3 616	4 424	5 071
1600	1 138	3 095	4 076	4 987	5 717
1800	1 305	3 420	4 503	5 510	6 316
2000	1 473	3 957	5 210	6 375	7 307
2200	1 640	4 493	5 917	7 239	8 298
2400	1 808	4 993	6 574	8 044	9 220
2600	1 975	5 492	7 232	8 848	10 142

55/45/20°C	Speed [-] / Heating output [W]				
Length [mm]	0	1	2	3	4 max
700	214	472	622	761	872
1000	354	951	1 253	1 533	1 757
1200	447	1 250	1 646	2 014	2 308
1400	540	1 528	2 012	2 461	2 821
1600	633	1 722	2 268	2 774	3 180
1800	726	1 903	2 505	3 065	3 514
2000	819	2 201	2 899	3 546	4 065
2200	912	2 500	3 292	4 027	4 616
2400	1 006	2 777	3 657	4 475	5 129
2600	1 099	3 055	4 023	4 922	5 642

Exponent n = 1,148

TZT - Heating output recalculation for another temperature gradient

To obtain the heating output for a different temperature gradient multiply heating output value at 75/65/20 °C by the below mentioned factor **f**.

Example

- Heating output of the convector TZT 0350 0138 1200 or temperature gradient 70/55°C
1. Output 75/65/20 °C = 1814 W
 2. Factor from the table for 70/55/20 °C at 138 width: f = 0,841
 3. Output 70/55/20 °C = f x 1814 = 1526 W

Height [mm]	90/70 °C	82/71 °C	70/55 °C	70/50 °C	50/40 °C
0350 0138	1,214	1,139	0,841	0,771	0,471
0350 0198	1,233	1,151	0,830	0,755	0,444

Room temperature 20 °C

Heating water flow rate through exchanger

To reach the required heating output we determine the desired flow of heating water through the convector exchanger. We calculate it from heating output of the convector for the selected input and output temperatures of heating water.

$$M = 0,86 * Q / (T1-T2) \text{ [kg / h]}$$

- M [kg/h] mass rate of flow, heating water flowing through exchanger
 Q [W] convector heating output
 T1-T2 [°C] difference between input and output temperature
 0,86 invariable for recalculation of units

Acoustic pressure [dB(A)]

Length [mm]	Speed [-] / Acoustic pressure [dB(A)]				
	0	1	2	3	4 max
700	-	<20	27	37	45
1000	-	22	30	40	45
1200	-	22	31	41	45
1400	-	22	31	41	45
1600	-	23	32	42	46
1800	-	24	33	43	47
2000	-	25	33	43	48
2200	-	26	34	44	49
2400	-	27	35	45	50
2600	-	28	36	46	51

Recalculation to other temperature gradients

Convector heating output reckoning follows by recalculation of the standardized output Q_n 75/65/20 °C

$$Q = Q_n * \Psi * (\Delta T / 50)^n \text{ [W]; where } \Delta T = ((T1+T2)/2) - T_i \text{ [°C]}$$

- Q_n [W] heating output for temperature gradient
 Ψ [-] mass rate of flow coefficient (for current flow rate $\Psi = 1$)
 T1 [°C] input water temperature
 T2 [°C] output water temperature
 Ti [°C] temperature in the room
 n [-] temperature exponent

Table of hydraulic parameters of exchangers

For hydraulic parameters of exchangers see the page 48.

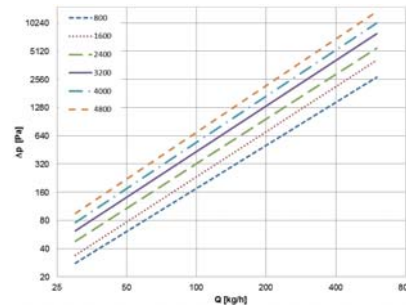

Fans input power [W]

Length [mm]	Speed [-] / Fans input power [W]				
	0	1	2	3	4 max
700	-	1 W	2 W	3 W	5 W
1000	-	2 W	3 W	6 W	9 W
1200	-	2 W	3 W	6 W	9 W
1400	-	3 W	6 W	10 W	17 W
1600	-	3 W	5 W	10 W	14 W
1800	-	4 W	6 W	12 W	17 W
2000	-	4 W	6 W	12 W	17 W
2200	-	4 W	7 W	13 W	18 W
2400	-	5 W	9 W	16 W	25 W
2600	-	6 W	11 W	20 W	33 W

* Approximate fan input powers /When using electrothermal actuator add in the convector's power 3 W

TST Fan-operated wall-mounted convector heaters

Fan-operated wall-mounted heaters are distinctive for their compact appearance. The rounded edges will perfectly complement both modern and historic interiors as well as environments with increased safety requirements. The electrothermal actuator for heating fluid flow control, as well as the water connection piping, is concealed inside the heater unit. The installed 24V DC fan effectively balances out extreme temperature variations experienced during winter by supplying a sufficient heat output, promptly responding to changes in temperature and securing high heat performance even when operated in low-temperature heating systems.

- Passive and low-energy houses
- Entrance areas, lobbies
- Shopping malls, airport lounges
- Schools, preschools
- Hospitals, retirement homes
- Institutions for people with reduced mobility
- Hotels



Standard Equipment

Cover	surface-treated steel sheet metal with an epoxy polyester powder coating
Grille	round or rectangular holes as per order specifications; grille is securely attached to the cover
Heat-exchanger	black painted Al-Cu lamellar heat-exchanger with a air vent valve, 2 × G1/2" inner threads
Fan	Modern tangential fan with 24 V DC EC motor with high efficiency, rotors protection
Valve	corner thermostatic valve, M30 x 1.5 thread with a 2.5 mm pitch
Mounting	wall brackets with connecting elements

Operating Conditions

Max. operating temp.	110°C
Max. operating excess pressure	1 MPa (10 bar)
Protection	IP20
Ambient conditions	temperature T = +2 to +40°C humidity Rh = 20 to 70%
Operating voltage	24 V DC

Convactor Heater Options and Size Variations

Standard valve connection V

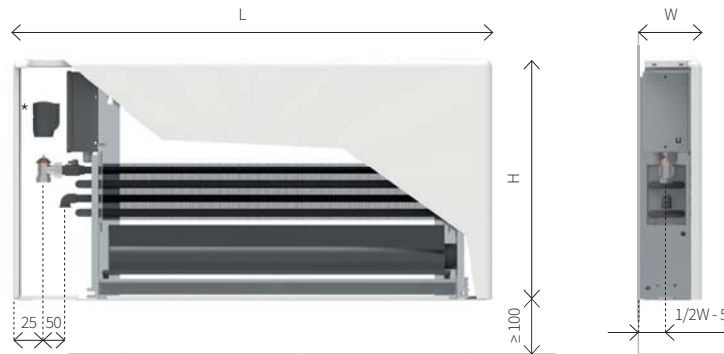

* electrothermal actuator not supplied with the heater

Convactor heater size variations

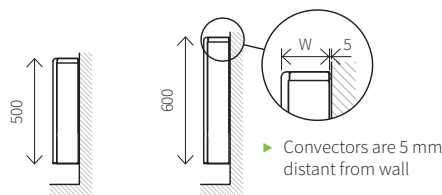

Height H [mm]	500	600
Width W [mm]	122	122
	182	182
Length L [mm]	700-2600	700-2600

Energy saving



Fan convectors operate on safe voltage of 24 V DC. The fan motors have very low consumption of electric power. The speed of fans is continuously commanded by controlling voltage of 0...10 V DC.

Component parts of the convector heater

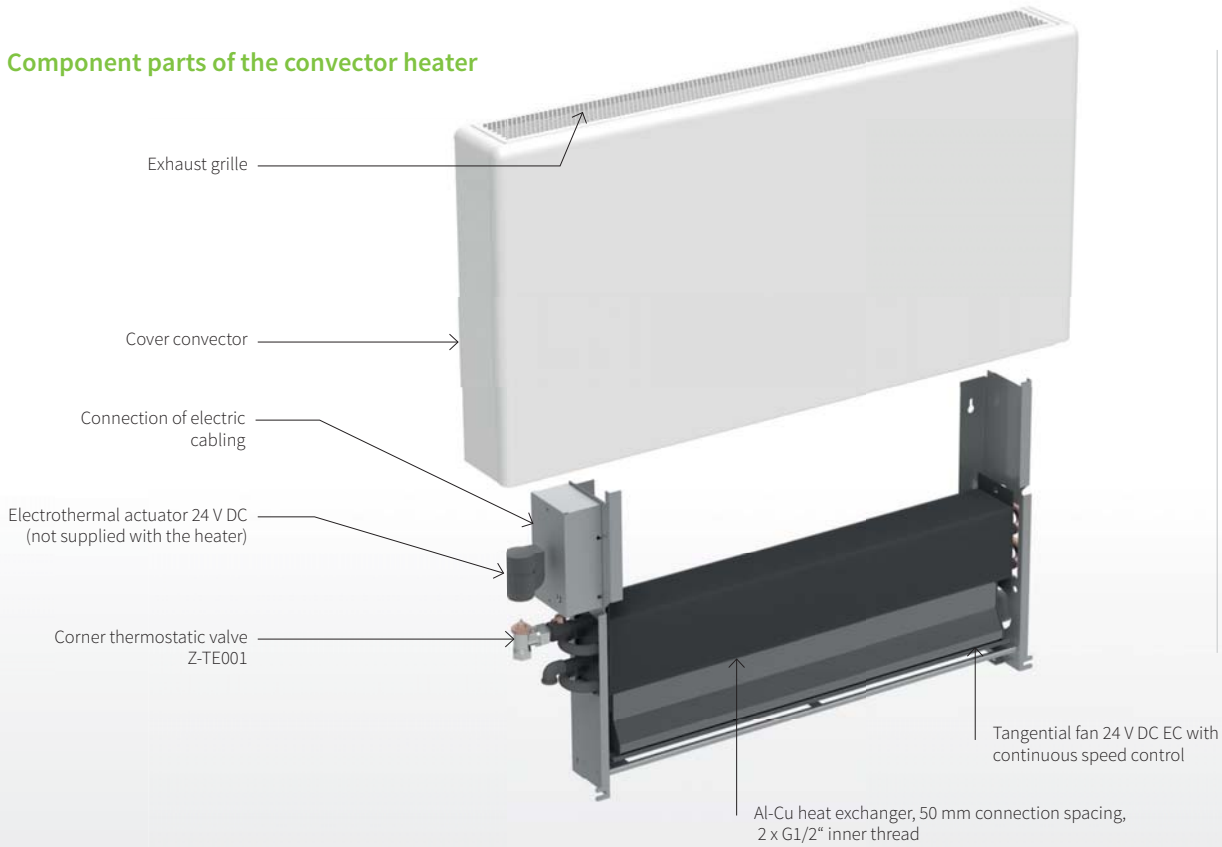

Accessories



► Details of accessories on the page 8

Grilles



Grille R
- rectangular holes

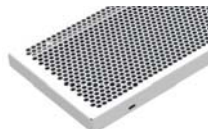

Grille C
- round holes

tip Order grilles and stands in colours that vary from the cover to brighten up your interior

► Options and grilles details, page 5

Brackets

W brackets

Wall brackets for attaching heat exchanger and convector cover are parts of the convector.



Number of brackets as per the body length

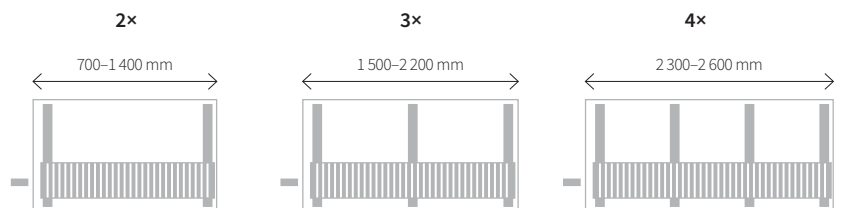

Coding

TST	0500	0182	1200	C	01	R	1	V	L	W	
Model	Height H	Width W	Length L	Material	Colour	Grille	Grille colour	Connection type	Connection side	Brackets	Atypical
TST	0500 mm 0600 mm	0122 mm 0182 mm	700 mm 1000 mm 1200 mm ... 2400 mm 2600 mm	C Sheet steel with surface finish and an epoxy polyester powder coating	As per RAL colour chart Structured colours Metallic paint colours See colour chart, page 57	R rectangular holes C round holes	1 Same as cover colour 9 Grille in different colour	V With corner thermostatic valve, bottom connection, 50 mm spacing	L Left side R Right side	W brackets for wall mounting	Empty position for standard A In non-standard heater configurations

► Other options, see page 59

← **Height 500 mm / Width 122 mm** →

75/65/20°C	Speed [-] / Heating output [W]				
Length [mm]	0	1	2	3	4 max
700	274	658	898	1 137	1 305
1000	452	1 325	1 810	2 291	2 629
1200	572	1 741	2 378	3 010	3 455
1400	691	2 128	2 907	3 679	4 222
1600	810	2 399	3 277	4 147	4 760
1800	929	2 651	3 620	4 582	5 259
2000	1 048	3 067	4 188	5 301	6 084
2200	1 167	3 483	4 756	6 020	6 909
2400	1 286	3 869	5 285	6 689	7 677
2600	1 405	4 256	5 813	7 358	8 444

55/45/20°C	Speed [-] / Heating output [W]				
Length [mm]	0	1	2	3	4 max
700	158	379	518	655	752
1000	261	764	1 043	1 320	1 515
1200	329	1 003	1 370	1 734	1 991
1400	398	1 226	1 675	2 120	2 433
1600	467	1 382	1 888	2 390	2 743
1800	535	1 527	2 086	2 640	3 030
2000	604	1 767	2 413	3 055	3 506
2200	672	2 007	2 741	3 469	3 981
2400	741	2 230	3 045	3 854	4 424
2600	810	2 453	3 350	4 240	4 866

Exponent n = 1,079

← **Height 500 mm / Width 182 mm** →

75/65/20°C	Speed [-] / Heating output [W]				
Length [mm]	0	1	2	3	4 max
700	474	815	1 101	1 359	1 558
1000	782	1 641	2 218	2 738	3 139
1200	988	2 156	2 914	3 598	4 125
1400	1 194	2 635	3 561	4 397	5 041
1600	1 400	2 971	4 015	4 957	5 683
1800	1 606	3 282	4 435	5 476	6 278
2000	1 812	3 797	5 131	6 336	7 264
2200	2 018	4 312	5 828	7 195	8 249
2400	2 224	4 791	6 475	7 995	9 166
2600	2 429	5 270	7 123	8 794	10 082

55/45/20°C	Speed [-] / Heating output [W]				
Length [mm]	0	1	2	3	4 max
700	272	468	633	782	896
1000	450	944	1 275	1 575	1 805
1200	568	1 240	1 676	2 069	2 372
1400	687	1 515	2 048	2 529	2 899
1600	805	1 708	2 309	2 851	3 268
1800	924	1 887	2 551	3 149	3 611
2000	1 042	2 184	2 951	3 644	4 177
2200	1 160	2 480	3 351	4 138	4 744
2400	1 279	2 755	3 724	4 598	5 271
2600	1 397	3 031	4 096	5 057	5 798

Exponent n = 1,083

← **Height 600 mm / Width 122 mm** →

75/65/20°C	Speed [-] / Heating output [W]				
Length [mm]	0	1	2	3	4 max
700	305	724	956	1 182	1 335
1000	505	1 459	1 926	2 382	2 690
1200	637	1 917	2 530	3 130	3 535
1400	770	2 343	3 092	3 825	4 320
1600	903	2 641	3 486	4 312	4 870
1800	1 036	2 918	3 851	4 764	5 381
2000	1 169	3 376	4 456	5 511	6 225
2200	1 301	3 834	5 060	6 259	7 069
2400	1 434	4 260	5 623	6 955	7 855
2600	1 567	4 686	6 185	7 650	8 640

55/45/20°C	Speed [-] / Heating output [W]				
Length [mm]	0	1	2	3	4 max
700	175	414	546	676	763
1000	288	834	1 101	1 361	1 538
1200	364	1 096	1 446	1 789	2 020
1400	440	1 339	1 768	2 186	2 469
1600	516	1 510	1 993	2 465	2 784
1800	592	1 668	2 201	2 723	3 075
2000	668	1 930	2 547	3 150	3 558
2200	744	2 192	2 892	3 578	4 041
2400	820	2 435	3 214	3 975	4 490
2600	896	2 679	3 535	4 373	4 939

Exponent n = 1,095

← **Height 600 mm / Width 182 mm** →

75/65/20°C	Speed [-] / Heating output [W]				
Length [mm]	0	1	2	3	4 max
700	484	897	1 171	1 413	1 594
1000	800	1 807	2 359	2 847	3 212
1200	1 011	2 374	3 100	3 741	4 220
1400	1 222	2 901	3 789	4 572	5 158
1600	1 432	3 271	4 271	5 154	5 815
1800	1 643	3 614	4 719	5 694	6 424
2000	1 853	4 181	5 459	6 587	7 432
2200	2 064	4 748	6 200	7 481	8 441
2400	2 275	5 275	6 889	8 312	9 378
2600	2 485	5 803	7 578	9 143	10 316

55/45/20°C	Speed [-] / Heating output [W]				
Length [mm]	0	1	2	3	4 max
700	275	510	666	804	907
1000	455	1 027	1 342	1 619	1 827
1200	575	1 350	1 763	2 127	2 400
1400	695	1 650	2 155	2 600	2 933
1600	814	1 860	2 429	2 931	3 307
1800	934	2 055	2 683	3 238	3 653
2000	1 054	2 377	3 105	3 746	4 227
2200	1 174	2 700	3 526	4 254	4 800
2400	1 294	3 000	3 917	4 727	5 333
2600	1 413	3 300	4 309	5 200	5 866

Exponent n = 1,105

TST - Heating output recalculation for another temperature gradient

To obtain the heating output for a different temperature gradient multiply heating output value at 75/65/20 °C by the below mentioned factor **f**.

Example

- Heating output of the convector TST 0500 0182 1400 for temperature gradient 70/55°C
1. Output 75/65/20 °C = 3561 W
 2. Factor from the table for 70/55/20 °C at 182 width: f = 0,839
 3. Output 70/55/20 °C = f x 3561 = 2988 W

Height [mm]	90/70 °C	82/71 °C	70/55 °C	70/50°C	50/40 °C
0500 0122	1,217	1,141	0,839	0,768	0,466
0500 0182	1,218	1,142	0,839	0,767	0,465
0600 0122	1,221	1,143	0,837	0,765	0,461
0600 0182	1,223	1,145	0,836	0,763	0,458

Room temperature 20 °C

Heating water flow rate through exchanger

To reach the required heating output we determine the desired flow of heating water through the convector exchanger. We calculate it from heating output of the convector for the selected input and output temperatures of heating water.

$$M = 0,86 * Q / (T1-T2) \text{ [kg / h]}$$

- M [kg/h] mass rate of flow, heating water flowing through exchanger
 Q [W] convector heating output
 T1-T2 [°C] difference between input and output temperature
 0,86 invariable for recalculation of units

Acoustic pressure [dB(A)]

Length [mm]	Speed [-] / Acoustic pressure [dB(A)]				
	0	1	2	3	4 max
700	-	<20	27	37	45
1000	-	22	30	40	45
1200	-	22	31	41	45
1400	-	22	31	41	45
1600	-	23	32	42	46
1800	-	24	33	43	47
2000	-	25	33	43	48
2200	-	26	34	44	49
2400	-	27	35	45	50
2600	-	28	36	46	51

Recalculation to other temperature gradients

Convector heating output reckoning follows by recalculation of the standardized output Q_n 75/65/20 °C

$$Q = Q_n * \Psi * (\Delta T / 50)^n \text{ [W]; where } \Delta T = ((T1+T2)/2) - T_i \text{ [°C]}$$

- Q_n [W] heating output for temperature gradient
 Ψ [-] mass rate of flow coefficient (for current flow rate $\Psi = 1$)
 T1 [°C] input water temperature
 T2 [°C] output water temperature
 Ti [°C] temperature in the room
 n [-] temperature exponent

Table of hydraulic parameters of exchangers

For hydraulic parameters of exchangers see the page 50.

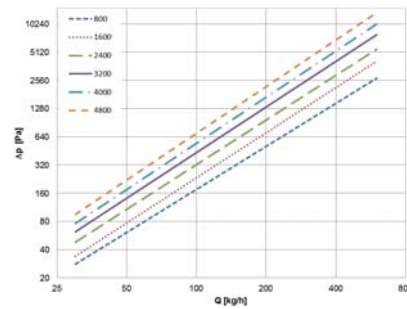

Fans input power [W]

Length [mm]	Speed [-] / Fans input power [W]				
	0	1	2	3	4 max
700	-	1 W	2 W	3 W	5 W
1000	-	2 W	3 W	6 W	9 W
1200	-	2 W	3 W	6 W	9 W
1400	-	3 W	6 W	10 W	17 W
1600	-	3 W	5 W	10 W	14 W
1800	-	4 W	6 W	12 W	17 W
2000	-	4 W	6 W	12 W	17 W
2200	-	4 W	7 W	13 W	18 W
2400	-	5 W	9 W	16 W	25 W
2600	-	6 W	11 W	20 W	33 W

* Approximate fan input powers /When using electrothermal actuator add in the convector's power 3 W

LBK Convector Bench

Self-standing convector with wooden bench. This unit allows you to sit down comfortably or put your belongings down.

It is ideal solution for public areas where the space in front of window is used both for heating and for people to rest i.e. waiting rooms, airports etc. Convactor bench is also perfectly suitable for the hallway in a family house.

This unit is a modified version of the LZK model. Solid beech board comes as standard, other type of wood like oak, maple or birch is available at request.

- public buildings, shopping malls
- hallways, gyms, dressing rooms
- lobbies, vestibules



Standard Equipment

Cover	surface-treated steel sheet metal with an epoxy polyester powder coating
Grille	round or rectangular holes as per order specifications; grille is securely attached to the cover
Heat-exchanger	Al-Cu lamellar heat-exchanger with a air vent valve, 2 × G1/2" inner connection threads
Valve	axial thermostatic valve, M30 x 1.5 thread with a 2.5 mm pitch (not supplied with side connection configuration)
Mounting	floor anchor stands as per order specifications
Board	wooden board, beech massive, varnished, with supports

Operating Conditions

Max. operating temp.	110°C
Max. operating excess pressure	1 MPa (10 bar)
Protection	IP20
Ambient conditions	temperature T = +2 to +40°C humidity Rh = 20 to 70%

Convactor Heater Options and Size Variations

Standard valve connection V

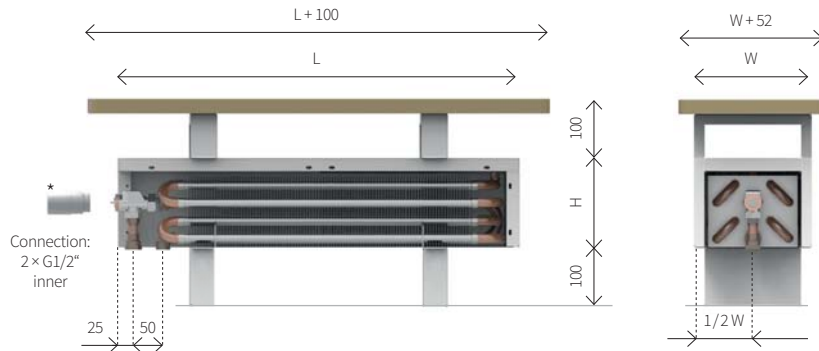

* Thermostatic head (not supplied with the heater)

Side connection B

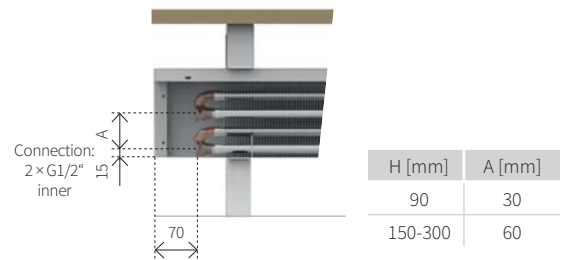

Convactor heater size variations

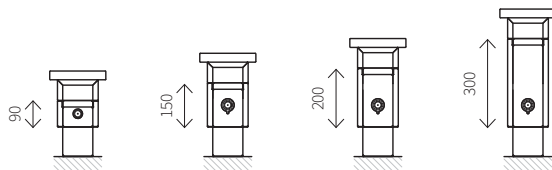

Height H [mm]	90	150	200	300
Width W [mm]	138	138	138	138
Length L [mm]	198	198	198	198
	258	258	258	258
Length L [mm]	400-2800	400-2800	400-2 800	400-2 800

Available wooden top designs

The top boards come in four versions made of solid wood. All boards are coated with a clear varnish. For other options, including the use of different wood or your own board, contact the ISAN Technical Department.



Note: Please specify any wood finish other than Beech natur in a note following the order code.

Component parts of the convector heater

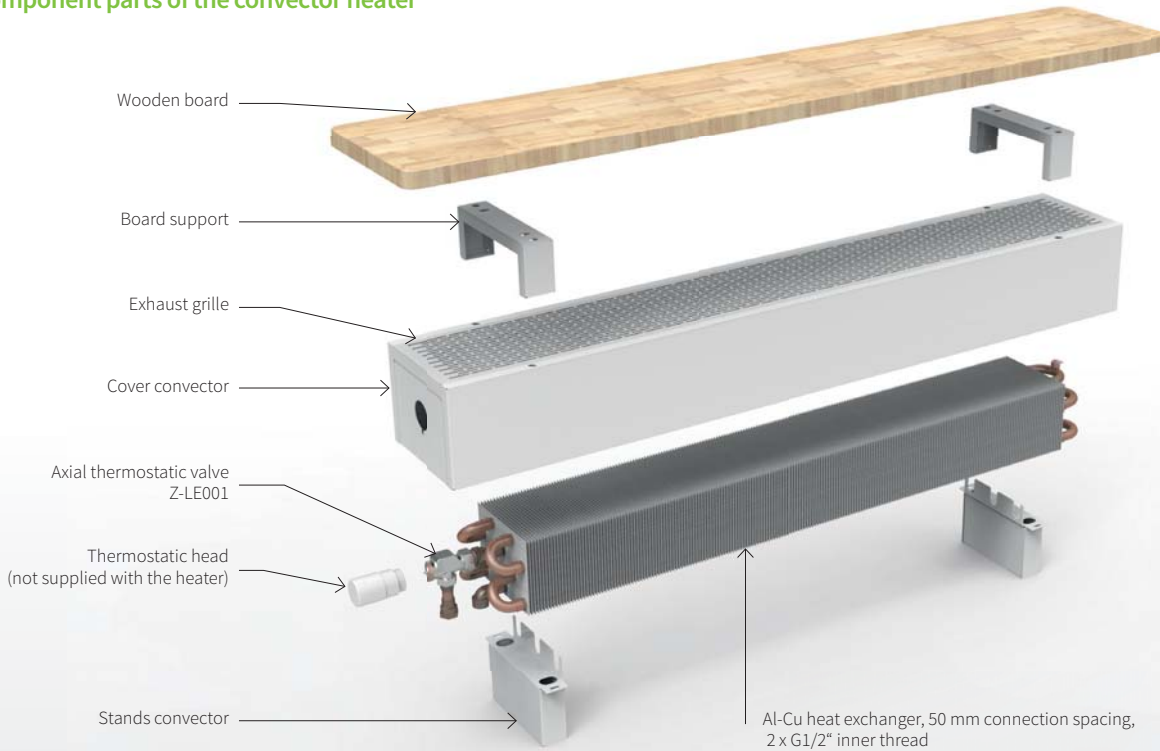

Accessories



► Details of accessories on the page 6

Grilles



Grille R
- rectangular holes

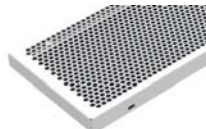

Grille C
- round holes

tip

Order grilles and stands in colours that vary from the cover to brighten up your interior

► Colour design options and grille details, page 5

Stands



Stand K
- floor mounting
- inconspicuous
- height 100 mm



Stand S
- self-standing model
- cover water piping
- height 100 mm

Number of stands as per the body length

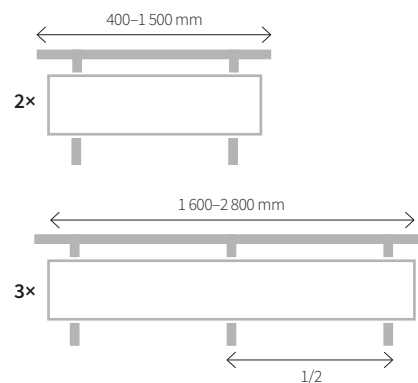

Coding

LBK	0150	0138	0400	C	01	R	1	V	L	K	
Model	Height H	Width W	Length L	Material	Colour	Grille	Grille colour	Connection type	Connection side	Stands	Atypical
LBK	0090 mm 0150 mm 0200 mm 0300 mm	0138 mm 0198 mm 0258 mm	0400 mm 0500 mm ... 1200 mm 1400 mm ... 2800 mm	C Sheet steel with surface finish and an epoxy polyester powder coating	As per RAL colour chart Structured colours Metallic paint colours See colour chart, page 57	R rectangular holes C round holes	1 Same as cover colour 9 Grille in different colour	V With axial thermostatic valve, bottom connection, 50 mm spacing B Side connection, 60 mm spacing, valve not included in the delivery	L Left side R Right side	K Inconspicuous, subtle S Water piping cover	Empty position for standard, wooden board: beech natur A In non-standard heater configurations or other wooden board (or both)

► Other options, see page 59

Atypical convector heaters

Design modifications of wall-mounted convector heaters

The design of convector heaters can be modified to meet your requirements. You can select from different grille setting options in the cover or models with the casing extended to the floor. Below are presented some basic modifications; for more options contact our Sales Department.

STANDARD DESIGN

LSK, TSK

The most common variation of a wall-mounted heat convector. The heaters look identical to panel radiators on the outside. A bottom protective grille is available to prevent tampering with convector heater components.



Coefficient **k = 1,00**

FORWARD EXHAUST

LDK, TDK

Convective heaters with a forward facing exhaust are often placed in environments with stricter hygiene requirements. It effectively prevents dust from entering the heater and accumulating on the heat-exchanger. The flat upper cover can be easily cleaned with a dust cloth. A bottom protective grille is available to prevent tampering with convector heater components.

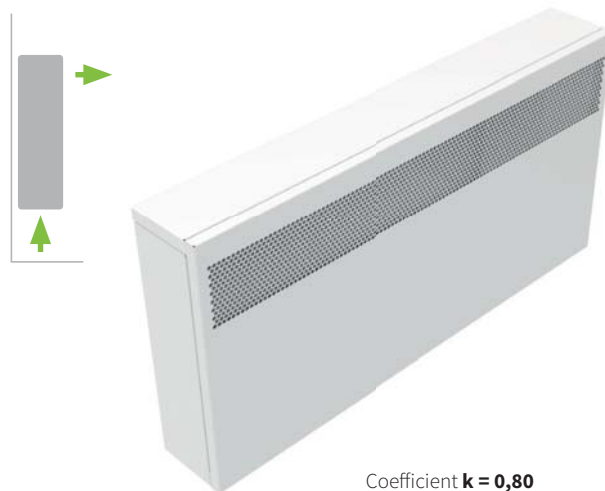

Coefficient **k = 0,80**

Coefficient **k** for recalculating heating output of modified convective versions. Multiply heating output by the mentioned coefficient.

Additional design variations

Front panel print design

The front panel can be adorned with a print design, giving free reign to imagination. Potential applications include photographs, logos, art work reproductions, various structures and geometric patterns, etc. There are no limits to creativity. The designer convective heater is ideal for both residential and public settings.



Ordering a decorative cover radiator:

E-mail us your graphic design, in the highest resolution possible. You will then be contacted for confirmation of the resolution, appearance, size and date of delivery. After this, manufacture of the heater will proceed and you will receive updated delivery information.

Atypical convector heaters

Design modifications of wall-mounted convector heaters

CASING EXTENDED TO THE FLOOR

LGK, TGK

A compact-looking unit with its casing extended to the floor. The heater seems to be standing directly on the floor. All internal components and connection piping are safely covered. The casing can be removed for cleaning purposes.



CASING EXTENDED TO THE FLOOR AND A FORWARD EXHAUST

LFK, TFK

This model combines the advantages of a full-height casing, with all internal components safely covered, and a forward-facing outlet which prevents accumulation of falling dust. Select the model with rounded corners for added safety.



Additional design variations

Convector heater with an integrated voltage supply LZP, TZP, LSP, TSP

In larger projects where simultaneous control of multiple convector heaters is required and individual cabling lengths are in tens of meters, it is advantageous to use convectors with an installed voltage supply. There is no need to dimension the network based on the power input as all convector heaters are powered by their own integrated voltage supply. It also provides a practical solution in projects where the final number of heaters in individual rooms is not known until the very last moment (e.g. when renting out floor space in shopping centers). The connection can be modified as required, while individual units can be readily separated and fitted with a thermostat.



Pressure loss for self-standing models

LZK, TZK width 138 mm / height 90 mm

Length [mm]	Volume [l]	M – mass rate of flow in piping (kg/h) / R – hydraulic loss in exchanger (kPa)									
		M = 40	60	80	100	150	200	250	300	350	400
600	0,2	0,003	0,008	0,017	0,029	0,075	0,146	0,243	0,367	0,519	0,700
800	0,4	0,005	0,012	0,023	0,038	0,094	0,177	0,289	0,430	0,600	0,802
1000	0,5	0,007	0,016	0,030	0,048	0,113	0,209	0,335	0,492	0,681	0,903
1200	0,6	0,009	0,020	0,036	0,057	0,133	0,240	0,381	0,554	0,762	1,004
1400	0,6	0,011	0,024	0,043	0,067	0,152	0,271	0,426	0,617	0,843	1,106
1600	0,7	0,012	0,028	0,049	0,076	0,171	0,303	0,472	0,679	0,924	1,207
1800	0,8	0,014	0,032	0,056	0,086	0,190	0,334	0,518	0,742	1,005	1,309
2000	0,9	0,016	0,036	0,062	0,095	0,209	0,365	0,564	0,804	1,086	1,410
2200	1,1	0,018	0,040	0,068	0,105	0,228	0,397	0,610	0,867	1,167	1,512
2400	1,2	0,020	0,043	0,075	0,114	0,247	0,428	0,656	0,929	1,249	1,613
2600	1,3	0,022	0,047	0,081	0,124	0,266	0,459	0,701	0,992	1,330	1,714
2800	1,4	0,024	0,051	0,088	0,133	0,286	0,491	0,747	1,054	1,411	1,816

LZK, TZK width 198 mm / height 90 mm

Length [mm]	Volume [l]	M – mass rate of flow in piping (kg/h) / R – hydraulic loss in exchanger (kPa)									
		M = 40	60	80	100	150	200	250	300	350	400
600	0,5	0,001	0,004	0,008	0,013	0,032	0,059	0,096	0,143	0,198	0,263
800	0,7	0,003	0,007	0,012	0,020	0,046	0,082	0,130	0,189	0,258	0,338
1000	0,9	0,004	0,010	0,017	0,027	0,059	0,105	0,164	0,235	0,318	0,414
1200	1,2	0,006	0,012	0,022	0,033	0,073	0,128	0,197	0,281	0,379	0,490
1400	1,2	0,007	0,015	0,026	0,040	0,087	0,150	0,231	0,327	0,439	0,566
1600	1,4	0,008	0,018	0,031	0,047	0,101	0,173	0,265	0,373	0,499	0,641
1800	1,6	0,010	0,021	0,036	0,054	0,115	0,196	0,298	0,419	0,559	0,717
2000	1,8	0,011	0,024	0,040	0,061	0,129	0,219	0,332	0,465	0,619	0,793
2200	2,1	0,013	0,027	0,045	0,068	0,143	0,242	0,365	0,511	0,679	0,869
2400	2,3	0,014	0,029	0,050	0,075	0,157	0,265	0,399	0,557	0,739	0,944
2600	2,5	0,015	0,032	0,054	0,082	0,171	0,288	0,433	0,603	0,799	1,020
2800	2,8	0,017	0,035	0,059	0,088	0,184	0,311	0,466	0,649	0,860	1,096

LZK, TZK width 258 mm / height 90 mm

Length [mm]	Volume [l]	M – mass rate of flow in piping (kg/h) / R – hydraulic loss in exchanger (kPa)									
		M = 40	60	80	100	150	200	250	300	350	400
600	0,6	0,010	0,022	0,038	0,058	0,128	0,225	0,346	0,493	0,664	0,859
800	0,8	0,013	0,029	0,050	0,077	0,167	0,289	0,441	0,623	0,835	1,076
1000	1,1	0,017	0,037	0,063	0,096	0,205	0,353	0,535	0,754	1,007	1,293
1200	1,4	0,021	0,044	0,076	0,115	0,244	0,416	0,630	0,884	1,178	1,510
1400	1,4	0,025	0,052	0,088	0,133	0,282	0,480	0,725	1,015	1,349	1,727
1600	1,7	0,028	0,060	0,101	0,152	0,320	0,544	0,819	1,146	1,521	1,944
1800	1,9	0,032	0,067	0,114	0,171	0,359	0,608	0,914	1,276	1,692	2,161
2000	2,2	0,036	0,075	0,126	0,190	0,397	0,672	1,009	1,407	1,863	2,378
2200	2,5	0,039	0,082	0,139	0,208	0,436	0,735	1,103	1,537	2,035	2,594
2400	2,8	0,043	0,090	0,152	0,227	0,474	0,799	1,198	1,668	2,206	2,811
2600	3,0	0,047	0,098	0,164	0,246	0,513	0,863	1,293	1,798	2,378	3,028
2800	3,3	0,051	0,105	0,177	0,265	0,551	0,927	1,387	1,929	2,549	3,245

LZK, TZK width 138 mm / height 150, 200, 300, 400, 500, 600 mm

Length [mm]	Volume [l]	M – mass rate of flow in piping (kg/h) / R – hydraulic loss in exchanger (kPa)									
		M = 40	60	80	100	150	200	250	300	350	400
600	0,5	0,026	0,055	0,096	0,147	0,316	0,545	0,831	1,172	1,568	2,016
800	0,7	0,033	0,071	0,121	0,183	0,390	0,664	1,005	1,408	1,874	2,399
1000	0,9	0,041	0,086	0,146	0,220	0,463	0,783	1,178	1,644	2,180	2,782
1200	1,2	0,049	0,102	0,172	0,257	0,536	0,902	1,352	1,880	2,486	3,165
1400	1,2	0,057	0,118	0,197	0,294	0,609	1,021	1,525	2,116	2,791	3,549
1600	1,4	0,065	0,133	0,222	0,331	0,682	1,140	1,698	2,352	3,097	3,932
1800	1,6	0,072	0,149	0,248	0,368	0,756	1,259	1,872	2,588	3,403	4,315
2000	1,9	0,080	0,164	0,273	0,405	0,829	1,378	2,045	2,824	3,709	4,698
2200	2,1	0,088	0,180	0,298	0,442	0,902	1,497	2,219	3,060	4,015	5,081
2400	2,3	0,096	0,195	0,323	0,478	0,975	1,616	2,392	3,296	4,321	5,464
2600	2,6	0,104	0,211	0,349	0,515	1,048	1,735	2,566	3,532	4,627	5,848
2800	2,8	0,111	0,226	0,374	0,552	1,122	1,854	2,739	3,767	4,933	6,231

LZT, TZT width 138 mm / height 350 mm

Length [mm]	Volume [l]	M – mass rate of flow in piping (kg/h) / R – hydraulic loss in exchanger (kPa)									
		M = 40	60	80	100	150	200	250	300	350	400
600	0,5	0,026	0,055	0,096	0,147	0,316	0,545	0,831	1,172	1,568	2,016
800	0,7	0,033	0,071	0,121	0,183	0,390	0,664	1,005	1,408	1,874	2,399
1000	0,9	0,041	0,086	0,146	0,220	0,463	0,783	1,178	1,644	2,180	2,782
1200	1,2	0,049	0,102	0,172	0,257	0,536	0,902	1,352	1,880	2,486	3,165
1400	1,2	0,057	0,118	0,197	0,294	0,609	1,021	1,525	2,116	2,791	3,549
1600	1,4	0,065	0,133	0,222	0,331	0,682	1,140	1,698	2,352	3,097	3,932
1800	1,6	0,072	0,149	0,248	0,368	0,756	1,259	1,872	2,588	3,403	4,315
2000	1,9	0,080	0,164	0,273	0,405	0,829	1,378	2,045	2,824	3,709	4,698
2200	2,1	0,088	0,180	0,298	0,442	0,902	1,497	2,219	3,060	4,015	5,081
2400	2,3	0,096	0,195	0,323	0,478	0,975	1,616	2,392	3,296	4,321	5,464
2600	2,6	0,104	0,211	0,349	0,515	1,048	1,735	2,566	3,532	4,627	5,848
2800	2,8	0,111	0,226	0,374	0,552	1,122	1,854	2,739	3,767	4,933	6,231

LZK, TZK width 198 mm / height 150, 200, 300, 400, 500, 600 mm

Length [mm]	Volume [l]	M – mass rate of flow in piping (kg/h) / R – hydraulic loss in exchanger (kPa)									
		M = 40	60	80	100	150	200	250	300	350	400
600	0,8	0,050	0,104	0,174	0,259	0,537	0,898	1,341	1,859	2,452	3,115
800	1,2	0,063	0,130	0,216	0,321	0,659	1,096	1,628	2,250	2,956	3,746
1000	1,6	0,077	0,157	0,259	0,383	0,781	1,295	1,916	2,639	3,461	4,377
1200	2,0	0,090	0,183	0,302	0,446	0,904	1,493	2,204	3,030	3,966	5,008
1400	2,3	0,104	0,210	0,345	0,508	1,026	1,691	2,491	3,420	4,471	5,639
1600	2,7	0,117	0,236	0,388	0,570	1,149	1,889	2,779	3,810	4,976	6,270
1800	3,1	0,131	0,263	0,430	0,632	1,271	2,087	3,067	4,200	5,481	6,901
2000	3,5	0,144	0,289	0,473	0,694	1,394	2,285	3,354	4,590	5,985	7,533
2200	3,9	0,158	0,315	0,516	0,757	1,516	2,483	3,642	4,980	6,490	8,164
2400	4,3	0,171	0,342	0,559	0,818	1,638	2,681	3,929	5,371	6,995	8,795
2600	4,7	0,184	0,368	0,602	0,881	1,761	2,879	4,217	5,760	7,500	9,426
2800	5,1	0,198	0,395	0,645	0,943	1,883	3,077	4,505	6,151	8,004	10,057

LZT, TZT width 198 mm / height 350 mm

Length [mm]	Volume [l]	M – mass rate of flow in piping (kg/h) / R – hydraulic loss in exchanger (kPa)									
		M = 40	60	80	100	150	200	250	300	350	400
600	0,8	0,050	0,104	0,174	0,259	0,537	0,898	1,341	1,859	2,452	3,115
800	1,2	0,063	0,130	0,216	0,321	0,659	1,096	1,628	2,250	2,956	3,746
1000	1,6	0,077	0,157	0,259	0,383	0,781	1,295	1,916	2,639	3,461	4,377
1200	2,0	0,090	0,183	0,302	0,446	0,904	1,493	2,204	3,030	3,966	5,008
1400	2,3	0,104	0,210	0,345	0,508	1,026	1,691	2,491	3,420	4,471	5,639
1600	2,7	0,117	0,236	0,388	0,570	1,149	1,889	2,779	3,810	4,976	6,270
1800	3,1	0,131	0,263	0,430	0,632	1,271	2,087	3,067	4,200	5,481	6,901
2000	3,5	0,144	0,289	0,473	0,694	1,394	2,285	3,354	4,590	5,985	7,533
2200	3,9	0,158	0,315	0,516	0,757	1,516	2,483	3,642	4,980	6,490	8,164
2400	4,3	0,171	0,342	0,559	0,818	1,638	2,681	3,929	5,371	6,995	8,795
2600	4,7	0,184	0,368	0,602	0,881	1,761	2,879	4,217	5,760	7,500	9,426
2800	5,1	0,198	0,395	0,645	0,943	1,883	3,077	4,505	6,151	8,004	10,057

LZK, TZK width 258 mm / height 150, 200, 300, 400, 500, 600 mm

Length [mm]	Volume [l]	M – mass rate of flow in piping (kg/h) / R – hydraulic loss in exchanger (kPa)									
		M = 40	60	80	100	150	200	250	300	350	400
600	1,1	0,074	0,151	0,250	0,371	0,758	1,256	1,859	2,561	3,357	4,243
800	1,6	0,093	0,188	0,312	0,459	0,932	1,536	2,264	3,108	4,062	5,122
1000	2,2	0,113	0,228	0,373	0,549	1,105	1,817	2,670	3,655	4,767	6,001
1200	2,7	0,132	0,265	0,436	0,639	1,281	2,097	3,075	4,202	5,472	6,880
1400	3,3	0,152	0,305	0,497	0,728	1,454	2,377	3,479	4,750	6,178	7,759
1600	3,8	0,171	0,342	0,559	0,817	1,630	2,658	3,885	5,296	6,884	8,638
1800	4,3	0,192	0,382	0,620	0,906	1,803	2,938	4,290	5,844	7,590	9,517
2000	4,9	0,210	0,419	0,683	0,996	1,979	3,219	4,694	6,390	8,295	10,396
2200	5,4	0,231	0,457	0,744	1,086	2,152	3,499	5,100	6,938	9,000	11,275
2400	6,0	0,251	0,496	0,806	1,174	2,326	3,779	5,505	7,485	9,705	12,154
2600	6,5	0,270	0,534	0,868	1,264	2,501	4,059	5,910	8,032	10,411	13,033
2800	7,1	0,290	0,573	0,930	1,353	2,675	4,339	6,315	8,579	11,116	13,912

Pressure loss for wall-mounted models

LSK, TSK width 82 mm / height 200, 300 mm

Length [mm]	Volume [l]	M – mass rate of flow in piping (kg/h) / R – hydraulic loss in exchanger (kPa)									
		M = 40	60	80	100	150	200	250	300	350	400
600	0,3	0,015	0,033	0,059	0,092	0,205	0,362	0,563	0,807	1,094	1,423
800	0,5	0,019	0,042	0,073	0,113	0,249	0,437	0,674	0,962	1,298	1,683
1000	0,6	0,023	0,050	0,088	0,135	0,294	0,511	0,786	1,116	1,502	1,942
1200	0,8	0,027	0,059	0,102	0,156	0,338	0,586	0,897	1,271	1,706	2,201
1400	0,8	0,031	0,067	0,116	0,177	0,383	0,661	1,009	1,425	1,910	2,460
1600	0,9	0,035	0,076	0,131	0,199	0,427	0,735	1,120	1,580	2,114	2,719
1800	1,1	0,039	0,084	0,145	0,220	0,472	0,810	1,232	1,735	2,317	2,978
2000	1,2	0,044	0,093	0,159	0,242	0,516	0,884	1,343	1,889	2,521	3,238
2200	1,4	0,048	0,102	0,174	0,263	0,561	0,959	1,454	2,044	2,725	3,497
2400	1,6	0,052	0,110	0,188	0,285	0,605	1,034	1,566	2,199	2,929	3,756
2600	1,7	0,056	0,119	0,202	0,306	0,650	1,108	1,677	2,353	3,133	4,015
2800	1,9	0,060	0,127	0,217	0,328	0,694	1,183	1,789	2,508	3,337	4,274

LSK, TSK width 82 mm / height 400, 500, 600 mm

Length [mm]	Volume [l]	M – mass rate of flow in piping (kg/h) / R – hydraulic loss in exchanger (kPa)									
		M = 40	60	80	100	150	200	250	300	350	400
600	0,6	0,037	0,079	0,134	0,202	0,427	0,724	1,091	1,525	2,022	2,582
800	0,9	0,048	0,100	0,169	0,253	0,526	0,885	1,324	1,839	2,429	3,089
1000	1,2	0,059	0,122	0,204	0,304	0,626	1,045	1,556	2,154	2,835	3,597
1200	1,6	0,070	0,144	0,239	0,354	0,725	1,206	1,789	2,469	3,241	4,104
1400	1,6	0,081	0,165	0,274	0,405	0,825	1,366	2,021	2,783	3,648	4,611
1600	1,9	0,092	0,187	0,309	0,456	0,924	1,527	2,254	3,098	4,054	5,118
1800	2,2	0,103	0,209	0,344	0,507	1,024	1,687	2,486	3,413	4,460	5,625
2000	2,5	0,114	0,230	0,379	0,557	1,124	1,848	2,719	3,727	4,867	6,132
2200	2,8	0,125	0,252	0,414	0,608	1,223	2,009	2,951	4,042	5,273	6,639
2400	3,1	0,136	0,274	0,449	0,659	1,323	2,169	3,184	4,357	5,680	7,147
2600	3,4	0,147	0,295	0,484	0,709	1,422	2,330	3,416	4,671	6,086	7,654
2800	3,7	0,159	0,317	0,519	0,760	1,522	2,490	3,649	4,986	6,492	8,161

LSK, TSK width 122 mm / height 165, 200, 300, 400, 500, 600 mm

Length [mm]	Volume [l]	M – mass rate of flow in piping (kg/h) / R – hydraulic loss in exchanger (kPa)									
		M = 40	60	80	100	150	200	250	300	350	400
600	0,5	0,026	0,055	0,096	0,147	0,316	0,545	0,831	1,172	1,568	2,016
800	0,7	0,033	0,071	0,121	0,183	0,390	0,664	1,005	1,408	1,874	2,399
1000	0,9	0,041	0,086	0,146	0,220	0,463	0,783	1,178	1,644	2,180	2,782
1200	1,2	0,049	0,102	0,172	0,257	0,536	0,902	1,352	1,880	2,486	3,165
1400	1,2	0,057	0,118	0,197	0,294	0,609	1,021	1,525	2,116	2,791	3,549
1600	1,4	0,065	0,133	0,222	0,331	0,682	1,140	1,698	2,352	3,097	3,932
1800	1,6	0,072	0,149	0,248	0,368	0,756	1,259	1,872	2,588	3,403	4,315
2000	1,9	0,080	0,164	0,273	0,405	0,829	1,378	2,045	2,824	3,709	4,698
2200	2,1	0,088	0,180	0,298	0,442	0,902	1,497	2,219	3,060	4,015	5,081
2400	2,3	0,096	0,195	0,323	0,478	0,975	1,616	2,392	3,296	4,321	5,464
2600	2,6	0,104	0,211	0,349	0,515	1,048	1,735	2,566	3,532	4,627	5,848
2800	2,8	0,111	0,226	0,374	0,552	1,122	1,854	2,739	3,767	4,933	6,231

LST, TST width 122 mm / height 500, 600 mm

Length [mm]	Volume [l]	M – mass rate of flow in piping (kg/h) / R – hydraulic loss in exchanger (kPa)									
		M = 40	60	80	100	150	200	250	300	350	400
600	0,5	0,026	0,055	0,096	0,147	0,316	0,545	0,831	1,172	1,568	2,016
800	0,7	0,033	0,071	0,121	0,183	0,390	0,664	1,005	1,408	1,874	2,399
1000	0,9	0,041	0,086	0,146	0,220	0,463	0,783	1,178	1,644	2,180	2,782
1200	1,2	0,049	0,102	0,172	0,257	0,536	0,902	1,352	1,880	2,486	3,165
1400	1,2	0,057	0,118	0,197	0,294	0,609	1,021	1,525	2,116	2,791	3,549
1600	1,4	0,065	0,133	0,222	0,331	0,682	1,140	1,698	2,352	3,097	3,932
1800	1,6	0,072	0,149	0,248	0,368	0,756	1,259	1,872	2,588	3,403	4,315
2000	1,9	0,080	0,164	0,273	0,405	0,829	1,378	2,045	2,824	3,709	4,698
2200	2,1	0,088	0,180	0,298	0,442	0,902	1,497	2,219	3,060	4,015	5,081
2400	2,3	0,096	0,195	0,323	0,478	0,975	1,616	2,392	3,296	4,321	5,464
2600	2,6	0,104	0,211	0,349	0,515	1,048	1,735	2,566	3,532	4,627	5,848
2800	2,8	0,111	0,226	0,374	0,552	1,122	1,854	2,739	3,767	4,933	6,231

LSK, TSK width 182 mm / height 165, 200, 300, 400, 500, 600 mm

Length [mm]	Volume [l]	M – mass rate of flow in piping (kg/h) / R – hydraulic loss in exchanger (kPa)									
		M = 40	60	80	100	150	200	250	300	350	400
600	0,8	0,050	0,104	0,174	0,259	0,537	0,898	1,341	1,859	2,452	3,115
800	1,2	0,063	0,130	0,216	0,321	0,659	1,096	1,628	2,250	2,956	3,746
1000	1,6	0,077	0,157	0,259	0,383	0,781	1,295	1,916	2,639	3,461	4,377
1200	2,0	0,090	0,183	0,302	0,446	0,904	1,493	2,204	3,030	3,966	5,008
1400	2,3	0,104	0,210	0,345	0,508	1,026	1,691	2,491	3,420	4,471	5,639
1600	2,7	0,117	0,236	0,388	0,570	1,149	1,889	2,779	3,810	4,976	6,270
1800	3,1	0,131	0,263	0,430	0,632	1,271	2,087	3,067	4,200	5,481	6,901
2000	3,5	0,144	0,289	0,473	0,694	1,394	2,285	3,354	4,590	5,985	7,533
2200	3,9	0,158	0,315	0,516	0,757	1,516	2,483	3,642	4,980	6,490	8,164
2400	4,3	0,171	0,342	0,559	0,818	1,638	2,681	3,929	5,371	6,995	8,795
2600	4,7	0,184	0,368	0,602	0,881	1,761	2,879	4,217	5,760	7,500	9,426
2800	5,1	0,198	0,395	0,645	0,943	1,883	3,077	4,505	6,151	8,004	10,057

LST, TST width 182 mm / height 500, 600 mm

Length [mm]	Volume [l]	M – mass rate of flow in piping (kg/h) / R – hydraulic loss in exchanger (kPa)									
		M = 40	60	80	100	150	200	250	300	350	400
600	0,8	0,050	0,104	0,174	0,259	0,537	0,898	1,341	1,859	2,452	3,115
800	1,2	0,063	0,130	0,216	0,321	0,659	1,096	1,628	2,250	2,956	3,746
1000	1,6	0,077	0,157	0,259	0,383	0,781	1,295	1,916	2,639	3,461	4,377
1200	2,0	0,090	0,183	0,302	0,446	0,904	1,493	2,204	3,030	3,966	5,008
1400	2,3	0,104	0,210	0,345	0,508	1,026	1,691	2,491	3,420	4,471	5,639
1600	2,7	0,117	0,236	0,388	0,570	1,149	1,889	2,779	3,810	4,976	6,270
1800	3,1	0,131	0,263	0,430	0,632	1,271	2,087	3,067	4,200	5,481	6,901
2000	3,5	0,144	0,289	0,473	0,694	1,394	2,285	3,354	4,590	5,985	7,533
2200	3,9	0,158	0,315	0,516	0,757	1,516	2,483	3,642	4,980	6,490	8,164
2400	4,3	0,171	0,342	0,559	0,818	1,638	2,681	3,929	5,371	6,995	8,795
2600	4,7	0,184	0,368	0,602	0,881	1,761	2,879	4,217	5,760	7,500	9,426
2800	5,1	0,198	0,395	0,645	0,943	1,883	3,077	4,505	6,151	8,004	10,057

LSK, TSK width 242 mm / height 165, 200, 300, 400, 500, 600 mm

Length [mm]	Volume [l]	M – mass rate of flow in piping (kg/h) / R – hydraulic loss in exchanger (kPa)									
		M = 40	60	80	100	150	200	250	300	350	400
600	1,1	0,074	0,151	0,250	0,371	0,758	1,256	1,859	2,561	3,357	4,243
800	1,6	0,093	0,188	0,312	0,459	0,932	1,536	2,264	3,108	4,062	5,122
1000	2,2	0,113	0,228	0,373	0,549	1,105	1,817	2,670	3,655	4,767	6,001
1200	2,7	0,132	0,265	0,436	0,639	1,281	2,097	3,075	4,202	5,472	6,880
1400	3,3	0,152	0,305	0,497	0,728	1,454	2,377	3,479	4,750	6,178	7,759
1600	3,8	0,171	0,342	0,559	0,817	1,630	2,658	3,885	5,296	6,884	8,638
1800	4,3	0,192	0,382	0,620	0,906	1,803	2,938	4,290	5,844	7,590	9,517
2000	4,9	0,210	0,419	0,683	0,996	1,979	3,219	4,694	6,390	8,295	10,396
2200	5,4	0,231	0,457	0,744	1,086	2,152	3,499	5,100	6,938	9,000	11,275
2400	6,0	0,251	0,496	0,806	1,174	2,326	3,779	5,505	7,485	9,705	12,154
2600	6,5	0,270	0,534	0,868	1,264	2,501	4,059	5,910	8,032	10,411	13,033
2800	7,1	0,290	0,573	0,930	1,353	2,675	4,339	6,315	8,579	11,116	13,912

Electrical diagram

SCHEME 1 - basic connection

Note

- The voltage must not drop below 22 V DC, it is necessary to size the cross section of conductors correctly according to the calculation SW.
- If more than 10 electrothermal actuators are used it is necessary to use the switching relay (see SCHEME 2).
- If the capacity of the switching source is insufficient use more power supplies (see SCHEME 3).

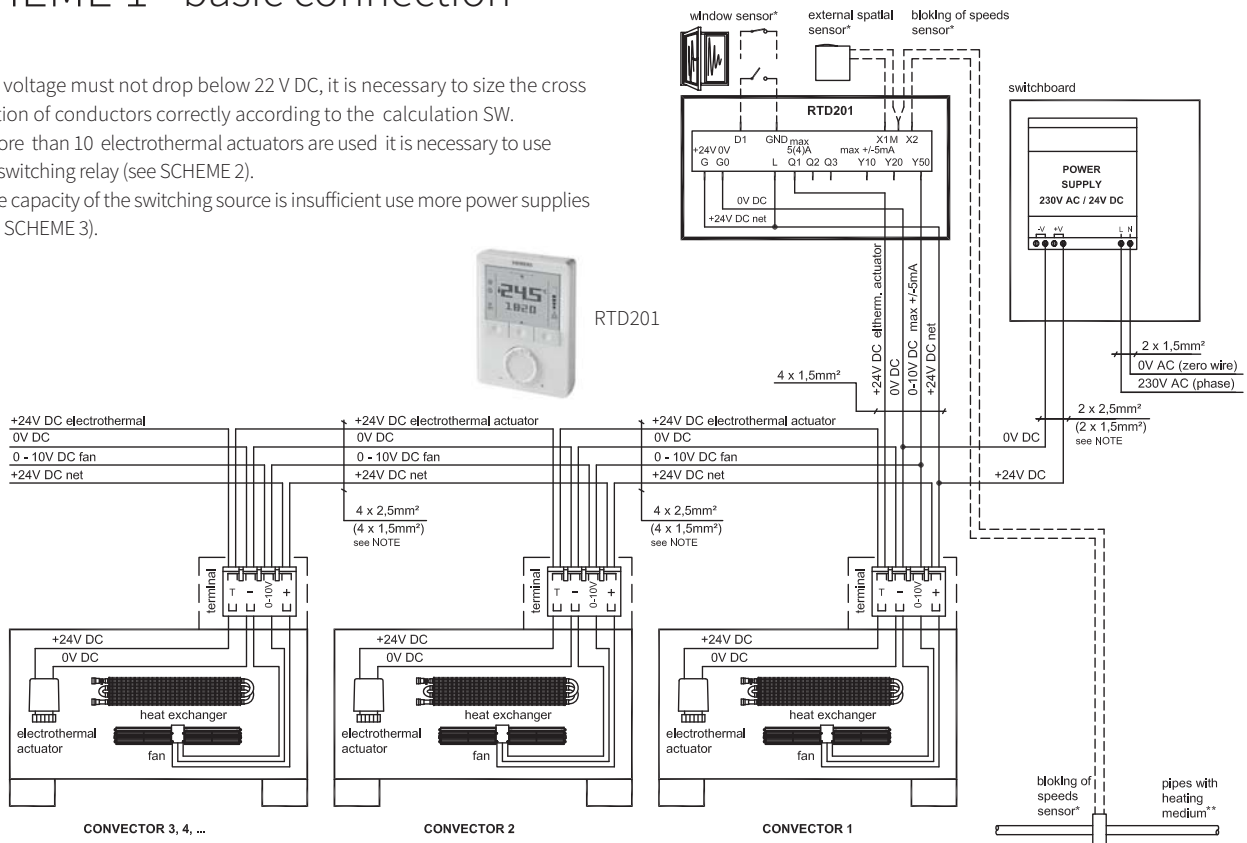

* accessories / ** The temperature sensor (block of revs) must be fixed on the tube, through which the heating medium freely flows and which is not closed by the actuator.

SCHEME 2 - connection with more than 10pcs of electrothermal actuator

Note

- The voltage must not drop below 22 V DC, it is necessary to size the cross section of conductors correctly according to the calculation SW.
- If the capacity of the switching source is insufficient use more power supplies (see SCHEME 3).

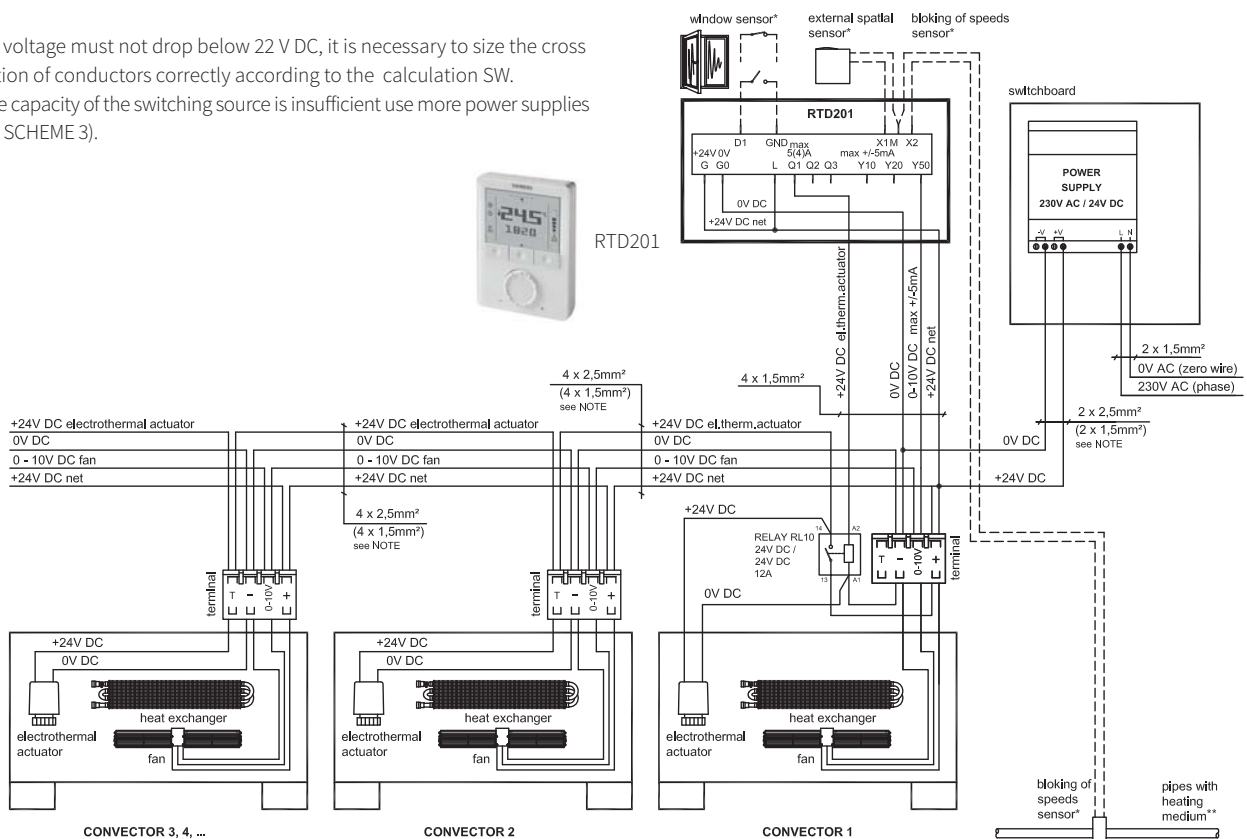

* accessories / ** The temperature sensor (block of revs) must be fixed on the tube, through which the heating medium freely flows and which is not closed by the actuator.

Electrical diagram

SCHEME 3 - connection with more supplies

Note

- The voltage must not drop below 22 V DC, it is necessary to size the cross section of conductors correctly according to the calculation SW.
- If more than 10 electrothermal actuators are used it is necessary to use the switching relay (see SCHEME 2).
- All sources shall be powered from a single circuit breaker.

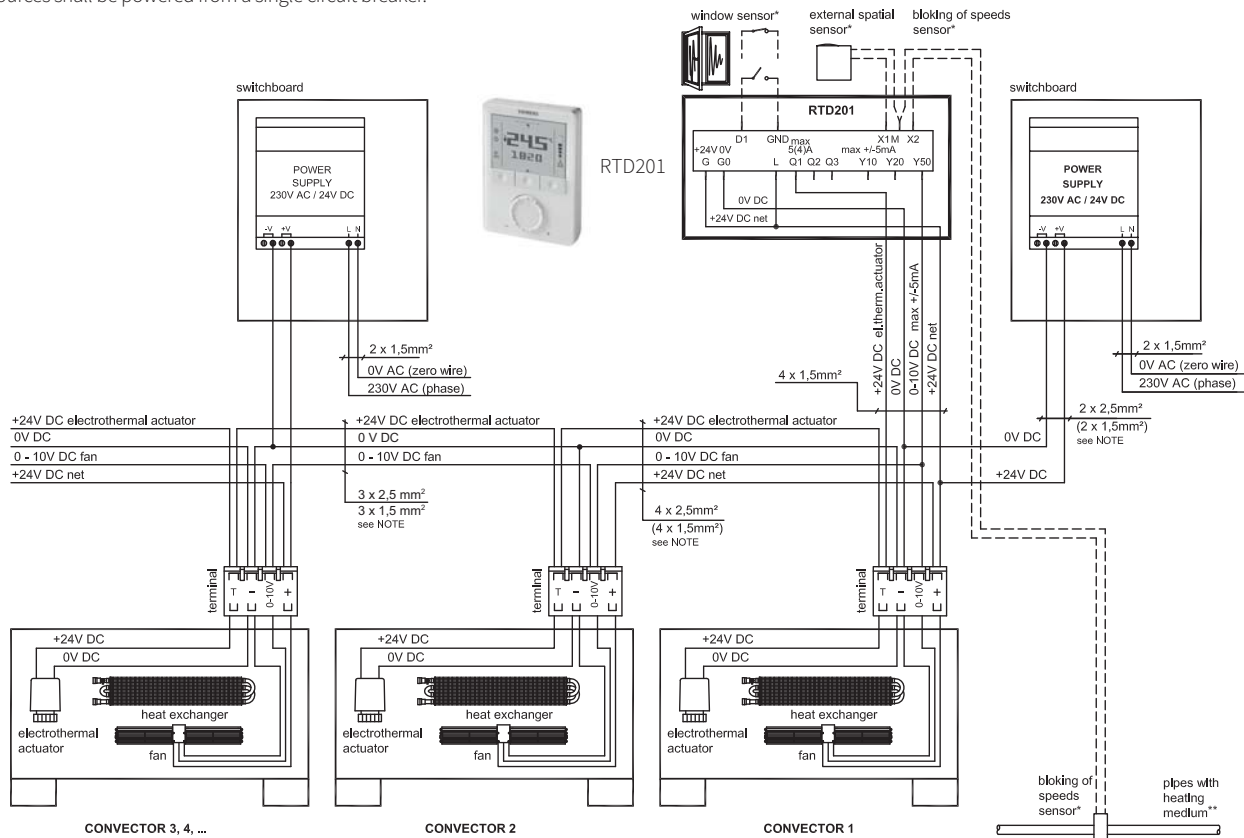

* accessories / ** The temperature sensor (block of revs) must be fixed on the tube, through which the heating medium freely flows and which is not closed by the actuator.

RTM201 thermostat connection

- The RTM201 thermostat is to be installed in accordance with RTD201 digital thermostat wiring diagrams, including the required parameters.
- Wiring connection to the RTM201 thermostat terminals.

Jumpers setting for the mode
Only heating

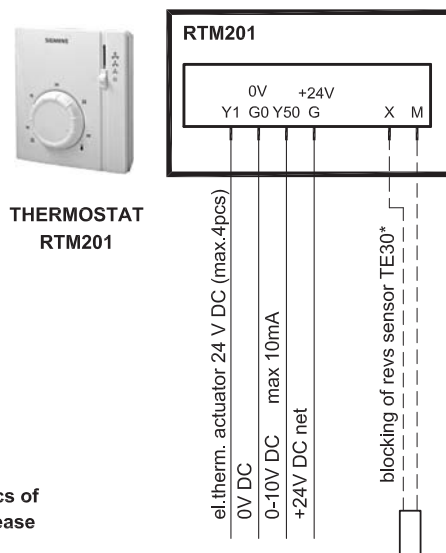
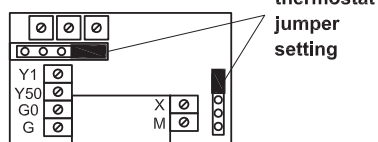

Note: Thermostat RTM201 can controll only 4 pcs of electrothermal actuator, for more pieces use please relay RL10, connection by Scheme 2

Acoustics

When planning fan-operated convectors fan for residential rooms it is necessary to take into account the acoustic characteristics of the convector and the environment in which it will be used. It is necessary to design a convector complying with the applicable standard, which defines acoustic limits for individual environments. The values are prescribed by a national directive, which shall be observed – there may be differences in individual EU states. In general one can say that the upper limit for a daily room is 40 dB(A), the limit for rooms with night or relaxation regime is lowered to 30 dB(A), the limit for offices is 50 dB(A) and so on.

Different requirements for different rooms

- entrance halls, corridors, waiting rooms, foyers
- office space, administrative rooms
- residential rooms, public buildings, car showrooms, shops
- rooms for relaxation and rest (residential rooms, bedrooms)

Acoustic parameters in the catalogue

The acoustic parameters specified in the Ecolite catalogue for individual products are valid for residential space “with standard equipment”. This means that the room is equipped in the standard way. Curtains, drapes, possibly Venetian blinds are fitted at windows, the floor or a part thereof is covered with a carpet, furniture is present. All these elements absorb or dissipate acoustic waves in the room.

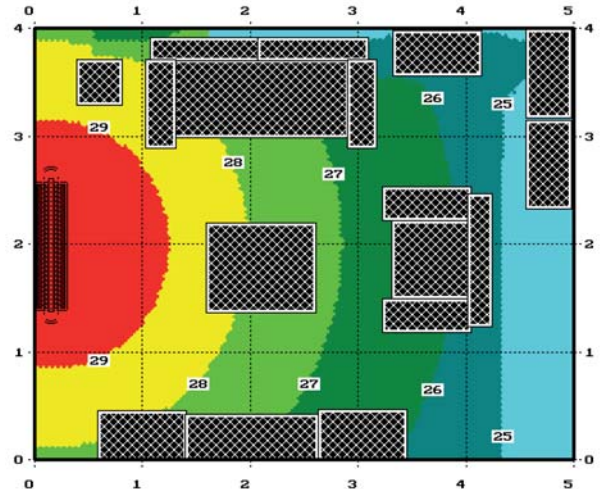

Changes and the influence on acoustic pressure

The type of space for which we design the Ecolite fan-operated convectors has fundamental influence on the total noise level of the environment connected with its operation. Reverberation occurs, resounding waves take relatively long time to die down (they are not absorbed), they mutually influence and magnify each other. The total level of acoustic pressure can be increased by as much as 3-6 dB(A).

- The undesirable effect of acoustic pressure is increased by convectors installed near corners or under ceiling without cover.
- rooms with minimalistic equipment without dampening elements and with a resounding floor without any cover have significant impact on the worsening of the total acoustics of the space. From the viewpoint of the assessment of the acoustic limit the influence of the room (with or without equipment) is not taken into consideration, the regulation assesses the fitness of the room in its current condition (at the time of measuring). In practice an empty room may be measured. Therefore the designer of the heating system shall take into account all possible variants of installation into a given space or he/she may draw the investor’s attention to available solutions using an alternative (more powerful, less noisy) convector in atypical cases.
- it is important to take into consideration acoustic parameters when installing more convector in a single room. Acoustic pressures of individual convectors mutually influence one another, resulting in an increase of the total noise level. It all depends on the type of the room, the characteristics of the convector and the distance between individual bodies. It is necessary to design heating bodies with a sufficiently low level of acoustic pressure at the selected output and the revs of the fan.

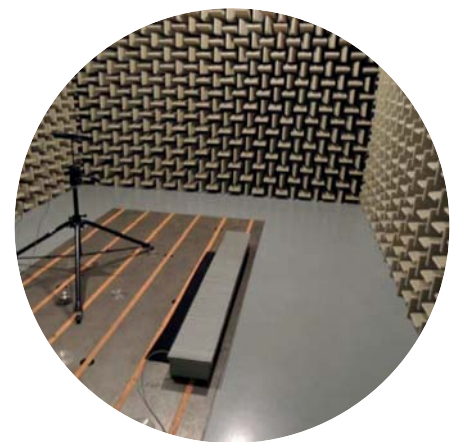

View of the testing acoustic chamber

The designer shall take into account all aspects of the room in which the convector is to be installed. (i.e. the equipment, dampening elements, floating or double-layer floor etc.)

Measuring the acoustic pressure

The measuring took place in semi-anechoic chamber. The acoustic chamber complies with ISO 3745 standard in terms of frequency range 100 Hz to 20 kHz. An accurate Brüel and Kjaer phonometer was used for measuring which complies with 1st category of measuring accuracy. The measuring methodology is based on the recommendations specified in the Methodology manual for noise measuring and assessment in non-working environment. Sensing device was placed diagonally one meter above the convector and 1 meter from the convector into the room. The values were adjusted to the conditions of a room with „standard equipment“ with standard reverberation and reflectance.

Orientation colour card

	<p>colour series RAL 9016 shade snow-white finish - extra charge - order code 01</p>		<p>colour series S09 shade snow-white finish texture extra charge - order code 68</p>		<p>colour series RAL 9001 shade ivory finish - extra charge - order code 04</p>
	<p>colour series S31 shade champagne finish metallic extra charge - order code 25</p>		<p>colour series RAL 9018 shade papyrus finish - extra charge - order code 14</p>		<p>colour series S08 shade ivory finish texture extra charge - order code 67</p>
	<p>colour series S26 shade lime finish - extra charge - order code 09</p>		<p>colour series S27 shade khaki finish texture extra charge - order code 21</p>		<p>colour series S36 shade antique gold finish metallic extra charge - order code 48</p>
	<p>colour series S32 shade pink coral finish texture extra charge - order code 26</p>		<p>colour series RAL 3002 shade fiery red finish - extra charge - order code 08</p>		<p>colour series S34 shade ruby finish - extra charge - order code 28</p>
	<p>colour series S13 shade sandstone finish texture extra charge - order code 72</p>		<p>colour series S28 shade gold olive finish texture extra charge - order code 22</p>		<p>colour series RAL 6021 shade linden green finish - extra charge - order code 06</p>
	<p>colour series S29 shade aquamarine finish metallic extra charge - order code 23</p>		<p>colour series RAL 5014 shade pigeon blue finish - extra charge - order code 07</p>		<p>colour series S30 shade sapphire finish texture extra charge - order code 24</p>
	<p>colour series S33 shade lava ash finish texture extra charge - order code 27</p>		<p>colour series S03 shade copper finish metallic extra charge - order code 62</p>		<p>colour series S19 shade brass finish metallic extra charge - order code 83</p>
	<p>colour series S38 shade dark grey finish texture extra charge - order code 50</p>		<p>colour series S05 shade silver finish metallic extra charge - order code 64</p>		<p>colour series S37 shade light grey finish texture extra charge - order code 49</p>
	<p>colour series S02 shade anthracite finish metallic extra charge - order code 61</p>		<p>colour series S35 shade cinnamon finish texture extra charge - order code 29</p>		<p>colour series S10 shade slate finish texture extra charge - order code 69</p>
					<p>colour series S40 shade black velvet finish mat extra charge - order code 51</p>

ECOLITE - coding for convector heaters with lamellar heat exchangers

1	2	3	4	5	6	7	8	9	10	11	12	13	14	15	16	17	18	19	20	21	22	23	24	
L	S	K	0	3	0	0	0	1	9	8	1	6	0	0	C	0	1	R	1	V	R	K	-	
Model	Type of construction	Convector type	Height [mm]				Width [mm]				Length [mm]				Convector casing	Casing colour		Grille type	Grille colour	Design	Heating fluid connection		Installation	Non-standard design

Code description

ECOLITE wall-mounted convector heater; square LSK model; HxWxL 300x198x1,600mm; steel casing – white spray paint RAL 9016; grille: rectangular with cut slots - colour matching the coating; valve-equipped; right-side connection; floor-mounted – block stands

1	MODEL	L	ECOLITE CUBE, convector heaters with a lamellar heat exchanger	
		T	ECOLITE ROUND, rounded corners, convector heaters with a lamellar heat exchanger	
2	TYPE OF CONSTRUCTION	Z	Self-standing convector heater, standard	
		B	Self-standing convector heater with wooden board	
		S	Wall-mounted convector heater, standard	
		D	Wall-mounted convector heater, bottom suction, forward exhaust	
		G	Wall-mounted convector heater, lower forward suction, top exhaust, wall-mounted convector with casing extended to the floor , position 23 "W"	
		F	Wall-mounted convector heater, lower forward suction, forward exhaust, wall-mounted convector with casing extended to the floor , position 23 "W"	
3	CONVECTOR TYPE	K	Natural convection heater	
		T	Fan-forced convection heater	
		P	Fan-forced convector with integrated voltage supply	
4-7	HEIGHT [mm]	0090	Self-standing: 0090, 0150, 0200, 0300, 0400, 0500, 0600 mm Fan-operated self-standing: 0350 mm	Wall-mounted: 0165, 0200, 0300, 0400, 0500, 0600 mm Fan-operated wall-mounted: 0500, 0600 mm
		...		
		0600		
8-11	WIDTH [mm]	0138	Self-standing: 0138, 0198, 0258 mm Fan-operated self-standing: 0138, 0198 mm	Wall-mounted: 0082, 0122, 0182, 0242 mm Fan-operated wall-mounted: 0122, 0182 mm
		...		
		0258		
12-15	LENGTH [mm]	0400	Self-standing and wall-mounted: 0400, 0500, 0600, 0700, 0800, 0900, 1000, 1100, 1200, 1400, 1600, 1800*, 2000*, 2200*, 2400*, 2600*, 2800* mm	
		...	Fan-operated self-standing and wall-mounted: 0700, 1000, 1200, 1600, 1800*, 2000*, 2200*, 2400*, 2600* mm	
		2800	*some lengths may be reduced by individual types	
16	CONVECTOR CASING	C	Sheet steel with a finish and epoxy polyester coating as per positions 17, 18	
17-18	CASING COLOUR	01	RAL9016 snow white	
		02	RAL9010 white	
		...	Other colour options, see page 57	
19	GRILLE TYPE	R	Rectangular grille slots	
		C	Round grille slots	
		L	Linear grille, available for L models only (CUBE)	
20	GRILLE COLOUR	1	Spray paint matching the casing (most common)	
		9	Colour different from the casing (specify in a note)	
		N	Al natur, anodized aluminium, available only for the linear grille L	
		B	Al bronze, anodized aluminium, available only for the linear grille L	
		C	Al black, anodized aluminium, available only for the linear grille L	
21	DESIGN	V	Valve design: self-standing and wall-mounted models with or without a fan, with a thermostatic valve, bottom connection with 50-mm spacing.	
		B	Side connection: self-standing and wall-mounted models, without control fitting, a heat exchanger with end pieces with 60-mm spacing.	
		Y	Wall connection, valve design, wall-mounted models only (not available for 82 mm width).	
		Z	Wall connection: no opening in the casing, wall-mounted models only (not available for 82 mm width).	
22	HEATING FLUID CONNECTION	L	Left-sided heating fluid connection	
		R	Right-sided heating fluid connection	
23	INSTALLATION	K	Block stands, not available for fan-operated self-standing units	
		S	Cover stands	
		H	Subfloor stands, not available for fan-operated self-standing units	
		W	Wall brackets (wall-mounted models only)	
24	ATYPICAL	A	For non-standard heater configurations	
			Empty position for a standard convector heater	



LAURENS
radiatoren & retro sanitair

Laurens Benelux bvba

Borgveld 1
3940 Hechtel-Eksel
België

Telefoon + 32 11 55 57 76
Fax + 32 11 55 57 78
E-mail: benelux@laurensint.com
www.laurens-radiatoren.be

